



**HENGE**

Being goes beyond the confines of dimensions.

Material is rediscovered in its essence and its intrinsic perfection, in the potentiality of a beauty that transcends the limits of lines. Material for material's sake, like art for art's sake, but transformed by the hands of those who interpret it and translate it into objects that define our relationship with life. An innate expressiveness so explosive as to manifest itself through the most subtle and airy signs of the contemporary, as much as in its most impressive extensions in space.

Henge's identity shines in a new mood that finds its elegant form in the lightness of being. The work done by Massimo Castagna for Mood 2017 is the pure expression of a research project, a journey that Henge, since its inception, has continued based on the materials and their uniqueness, their imperfections and their possible ways of being.

These possibilities take concrete shape through the Made in Italy craftsmanship of artisans who forge new relationships between ancient skills and modern technologies. Their pieces have a crystalline soul and establish a unique way of communicating and connecting with the world around us. The organic forms of the special collaboration with George Yabu and Glenn Pushelberg of the Yabu Pushelberg Studio come together in this material project – the creation of the exclusive Mushroom Tables – that embraces the Henge philosophy by following subtle lines and using important materials.

Mood 2017 by Henge is a vision of interior design not easily labeled: a constant evolution that interprets the natural cycles of an organic world, a path to be followed for its links with the past and the interpretation it offers of the dreams of today and of tomorrow, becoming a part and a cause of change.

L'essere supera i confini delle dimensioni.

La materia si riscopre nella sua essenza e nell'intrinseco della sua perfezione, nella potenzialità di una bellezza che trascende i limiti delle linee. La materia per la materia, come l'arte per l'arte, ma trasformata dalle mani di chi la interpreta e la traduce in oggetti che definiscono la nostra relazione con la vita. Un'espressività innata così dirompente da manifestarsi attraverso i più sottili e ariosi segni contemporanee tanto quanto nelle sue più imponenti estensioni nello spazio.

L'identità di Henge si irradia in un nuovo mood che trova nella leggerezza dell'essere la sua forma di eleganza. Il lavoro portato avanti da Massimo Castagna per il mood 2017 è la pura espressione di un progetto di ricerca, un viaggio che Henge porta avanti dalla sua nascita all'interno della materia e della sua unicità, delle sue imperfezioni e le sue

possibilità di essere. Possibilità che trovano una concreta esistenza nelle lavorazioni degli artigiani del Made in Italy, le cui tecniche antiche approfondiscono nuovi rapporti con le tecnologie moderne, creando pezzi dall'anima limpida che stabiliscono un modo unico di comunicarsi e mettersi in contatto con il mondo intorno. In questo progetto materico si innestano le forme organiche della speciale collaborazione con George Yabu e Glenn Pushelberg, dello studio Yabu Pushelberg: gli esclusivi Mushroom tables sposano la filosofia di Henge seguendo tratti sottili e materiali di spessore.

Il mood 2017 di Henge è una visione sul design d'interni difficile da etichettare: un'evoluzione costante che interpreta i cicli naturali di un mondo organico, un percorso da seguire per le sue congruenze con il passato e per l'interpretazione che dà dei sogni dell'oggi e del domani, diventando parte e motivo del cambiamento.



Time is a continuum, a constant evolution to be embraced, where what is new opens the door to other infinite possibilities.



The past is part of the present, just as the future is already in the here and now.  
Mood 2017 preserves the traces of Henge's history and links them to its future.



The Henge home is transformed according to contemporary forms and combinations, while its own DNA changes gradually by adding elements and directions in its search for design evolution.

Salone del Mobile 2017

**HENGE**





*At the Salone del Mobile 2017, the material flows through structures freed from heaviness, expressing itself through unique materials and the finest craftsmanship*





















*Mood 2017 is the incarnation of Henge's design,  
knowledge and its ability to play with space*













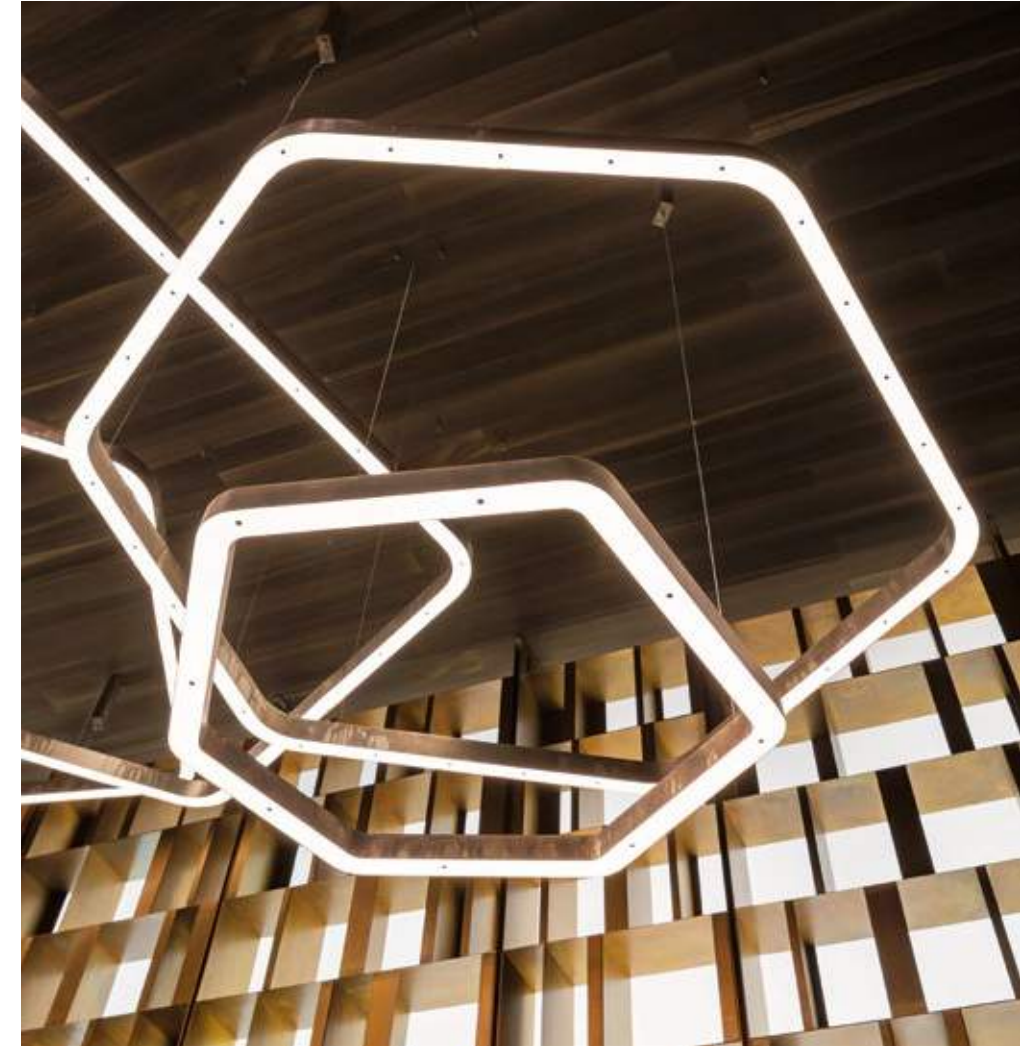



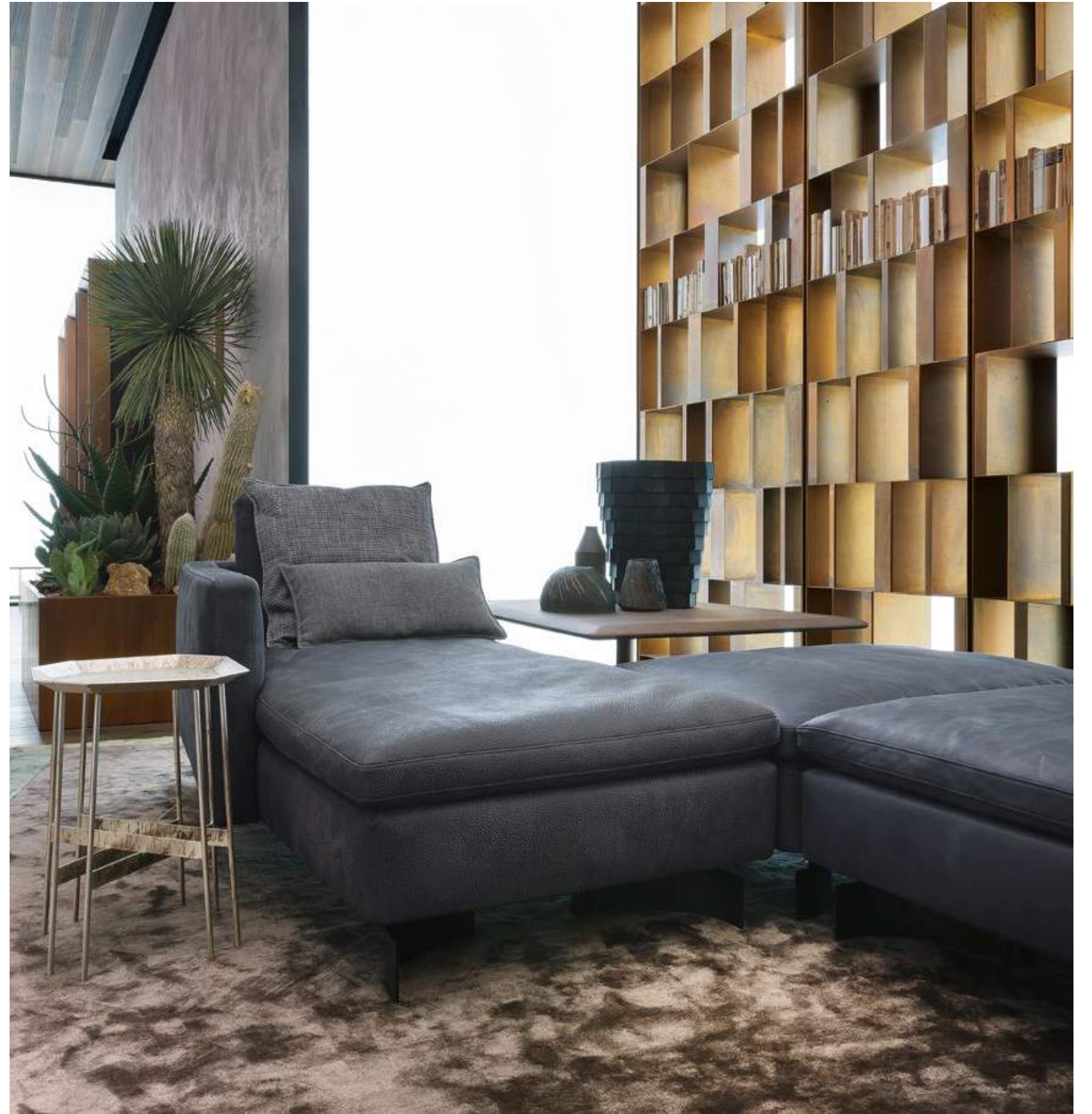



The exhibition space at the Salone del Mobile is captivating for its elegant lightness in a place of color contrasts and suspended volumes







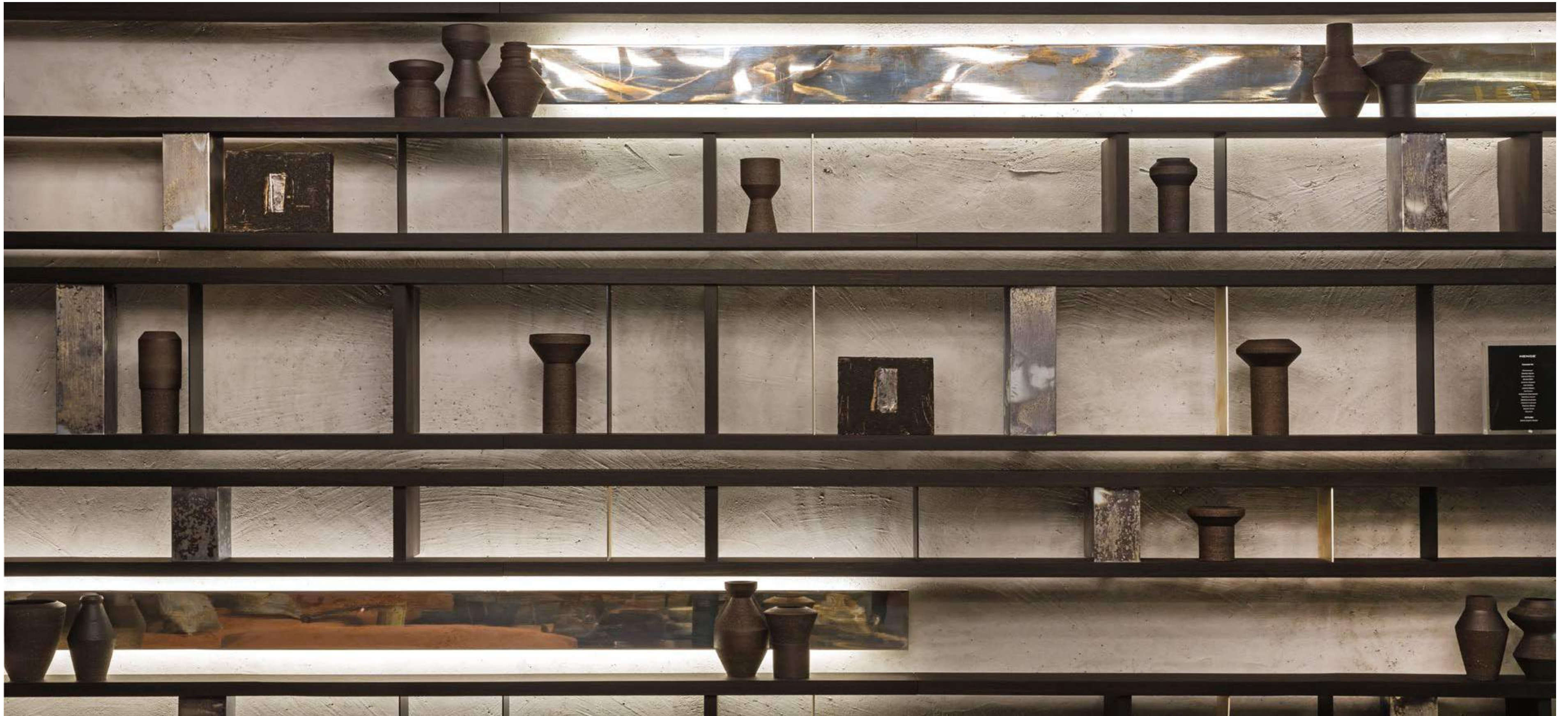









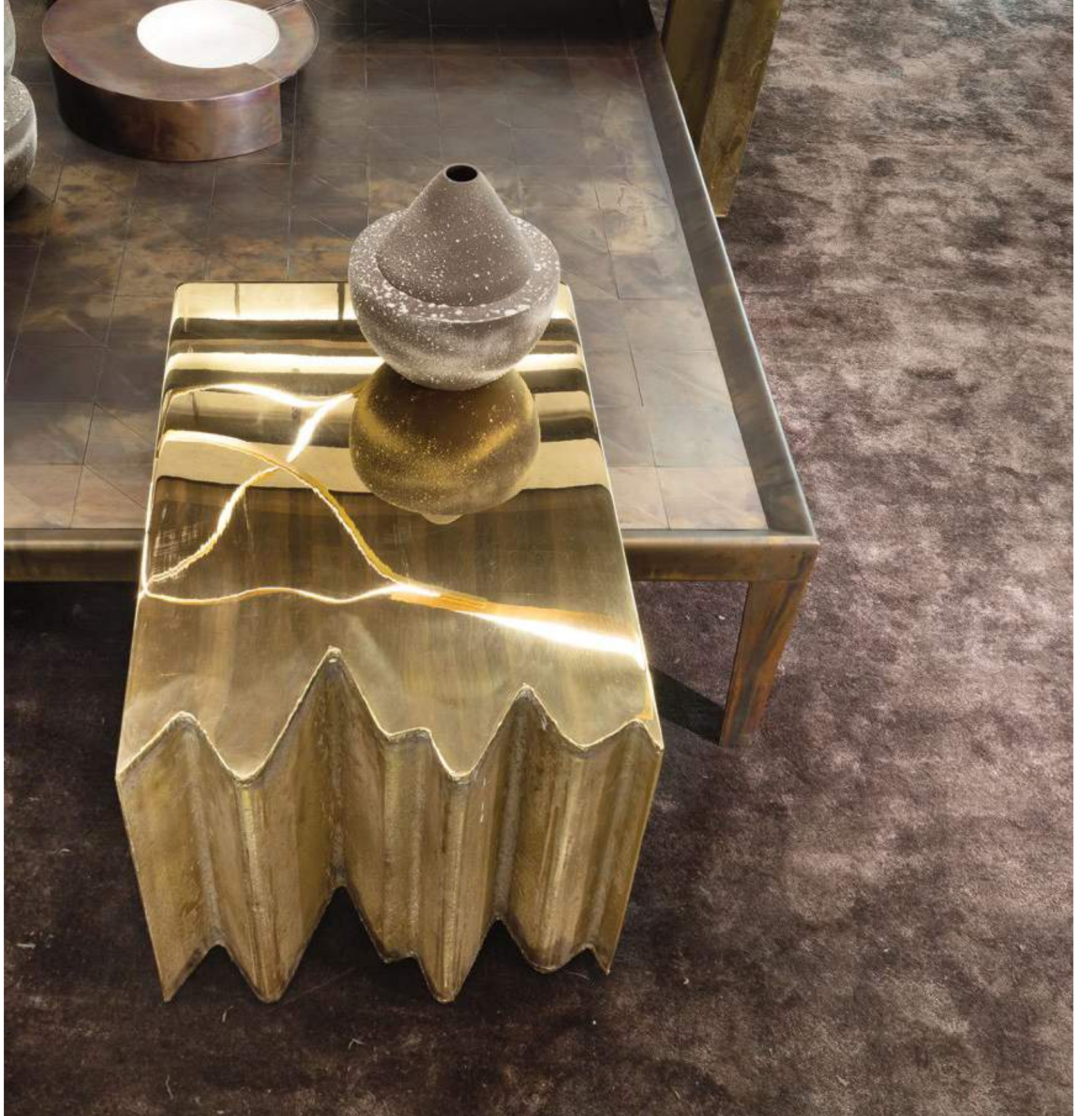





Via della Spiga 2017

Mood 2017 redesigns the sensorial experience of the space at 7 Via della Spiga into a living, organic project that reinvents itself year-after-year, inspired by the material vibrations of Henge









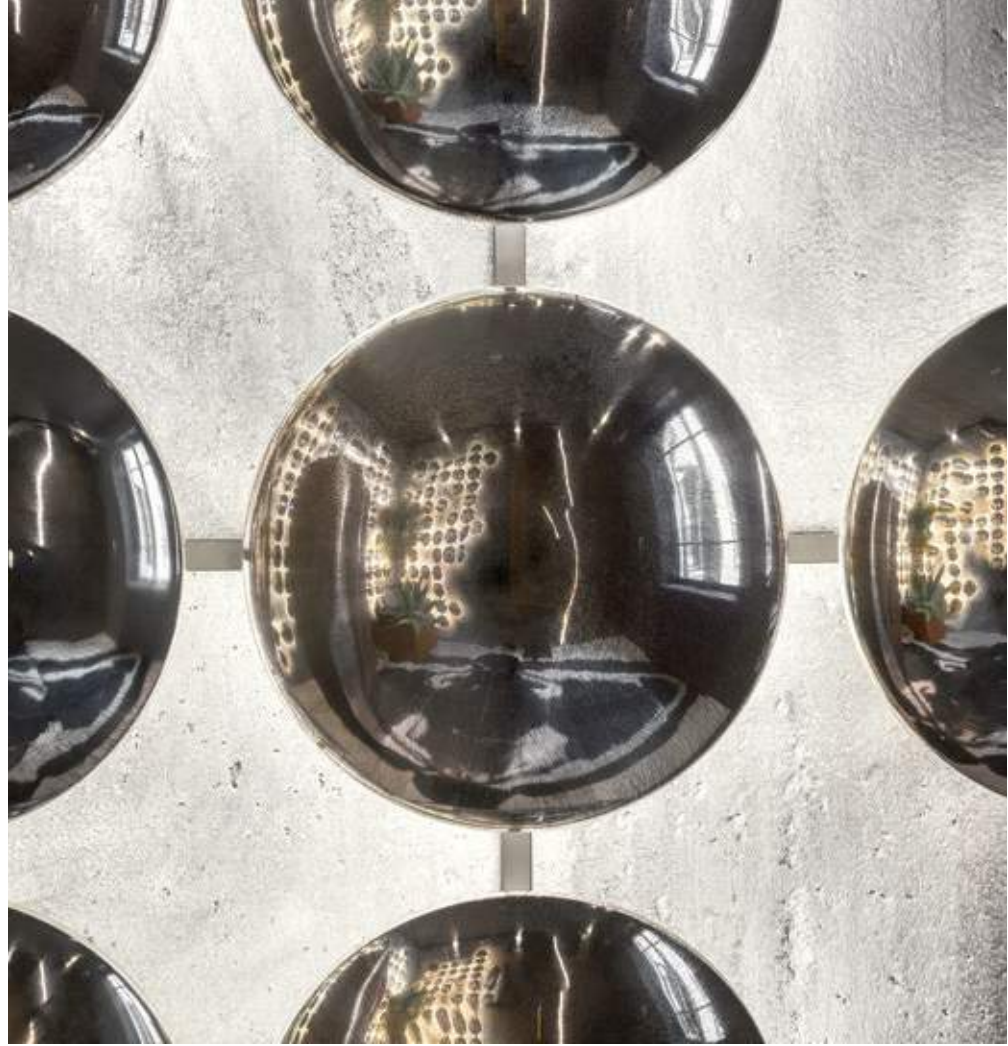

A space that balances sophisticated design,  
artistic inspiration, unexpected material  
combinations and pure Made in Italy  
craftsmanship and technology



















The expressive skills and expertise of Henge's craftsmanship break away from what is standard and inherit the value of authentic originality



VIA DELLA SPIGA 2017

# Radical Living Room

- 01. Radical Sofa - Nabuk Stone 17
- 02. Strip Lounge Armchair - Burnished Brass, Camoscio 36
- 03. Touch Coffee Table - Burnished Brass, Oak Thermowood
- 04. Galaxy Maxi Coffee Table - Burnished Brass
- 05. Cage-B S - Burnished Brass, Black Eucalyptus
- 06. Tape Light - Burnished Brass
- 07. Light Ring Horizontal - Burnished Brass, Black Eucalyptus
- 08. Tele Light - Burnished Brass

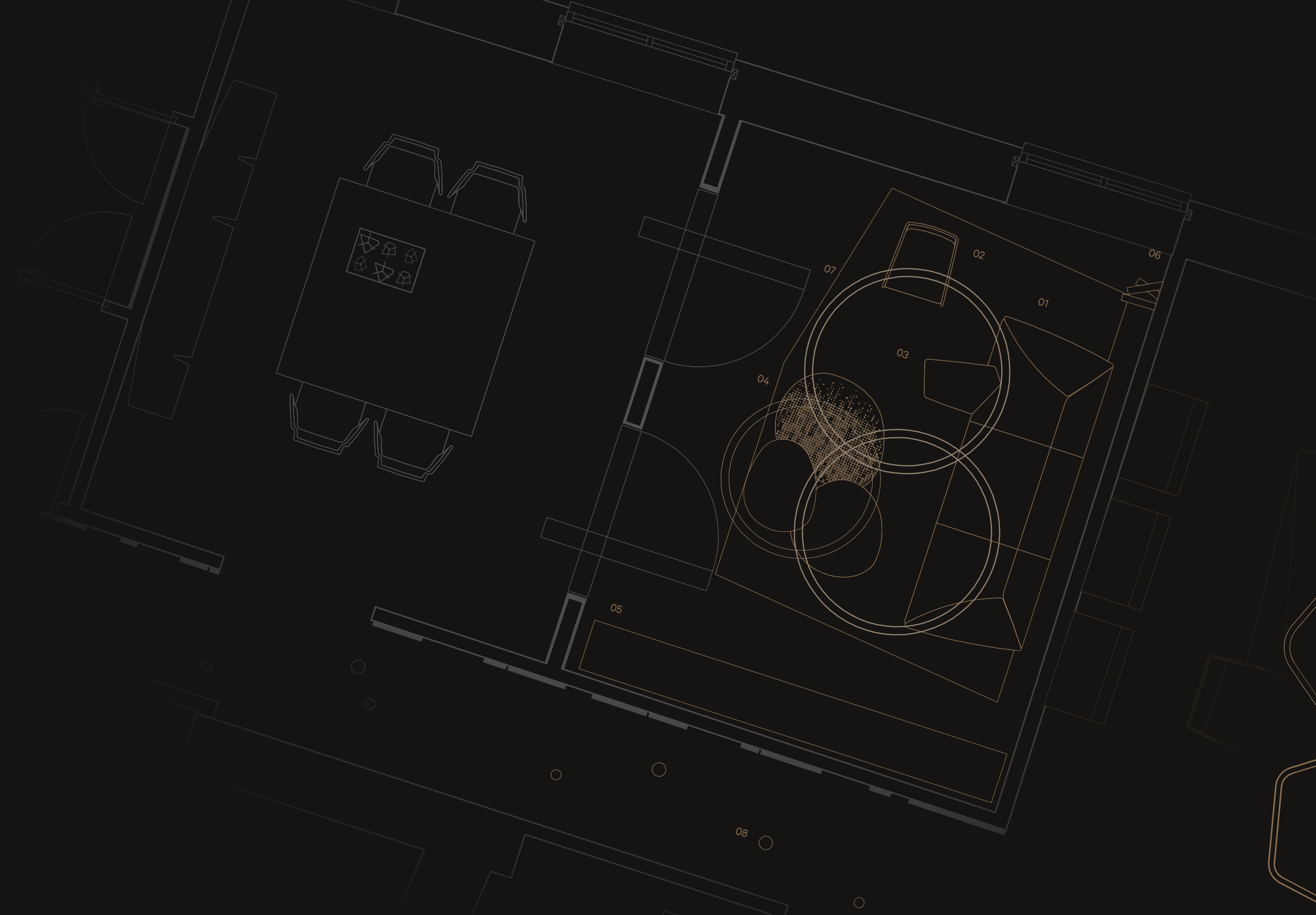















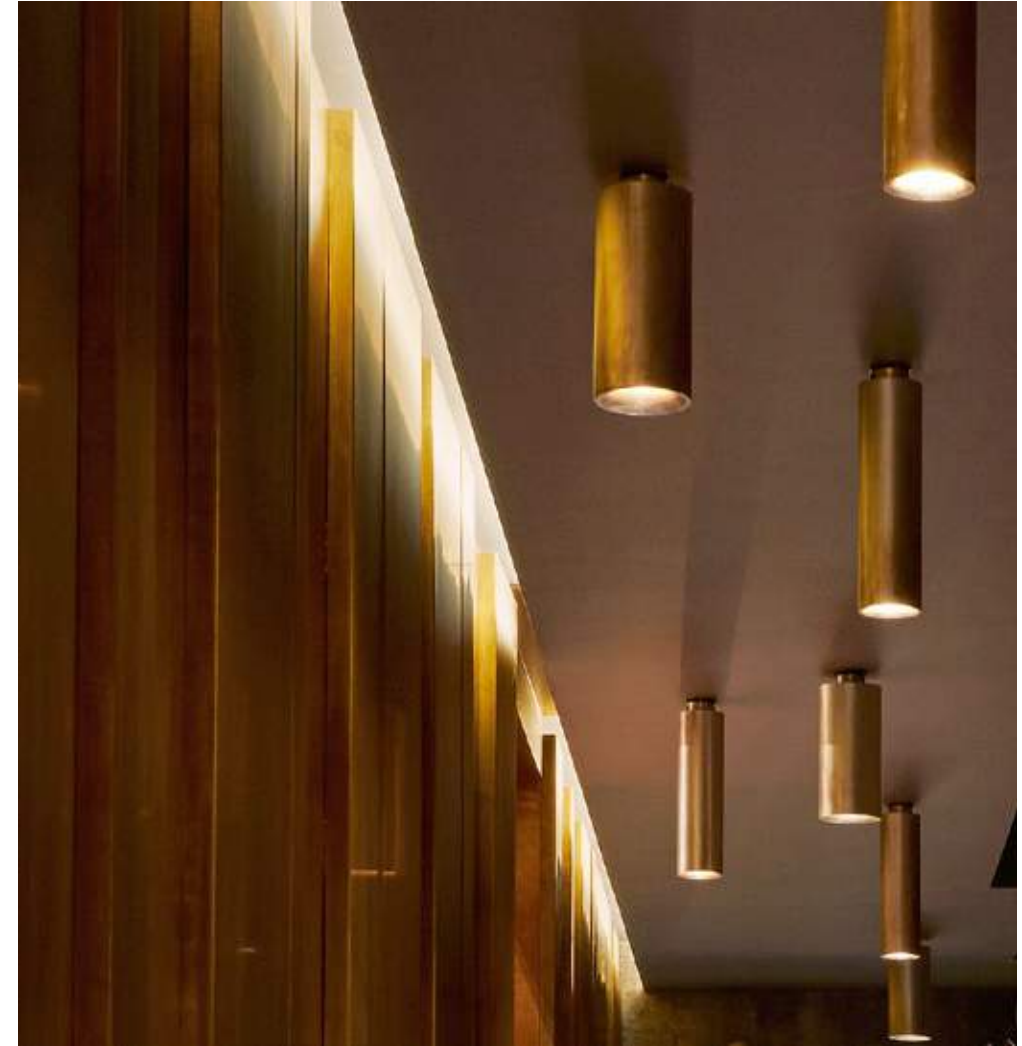

*Mood 2017 merges with the spaces  
of 7 Via della Spiga to represent Henge's vision  
of the contemporary, interpreted through  
the eyes of Massimo Castagna*

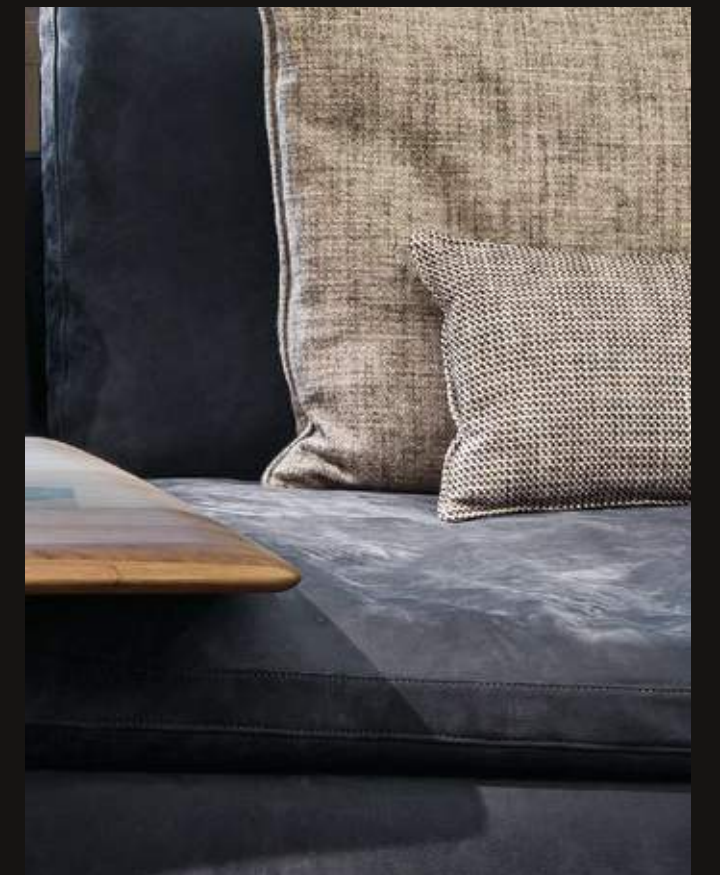







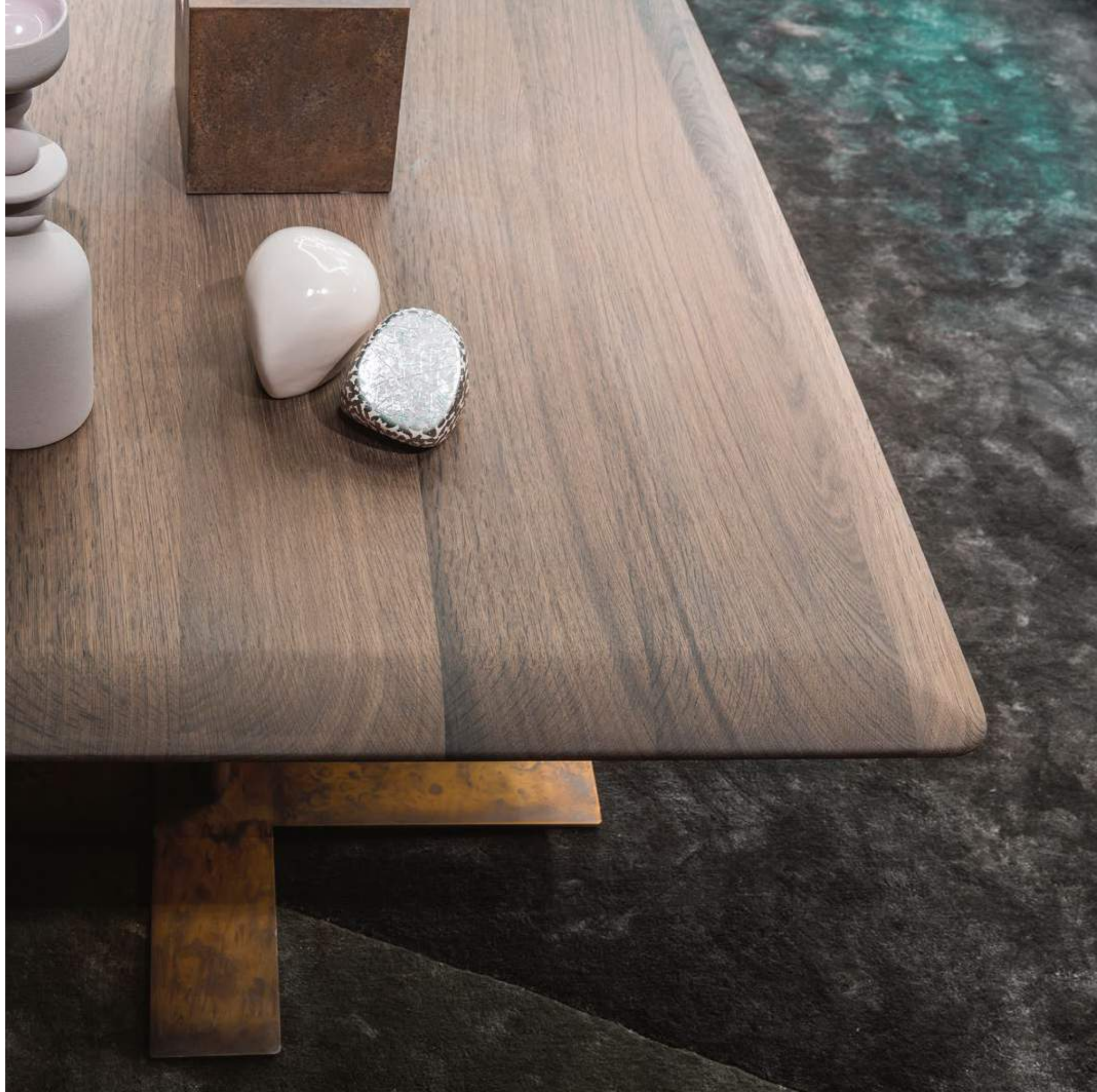













Massimo Castagna's new collection  
is an analytical look at man's relationship  
with his dimension of interior space















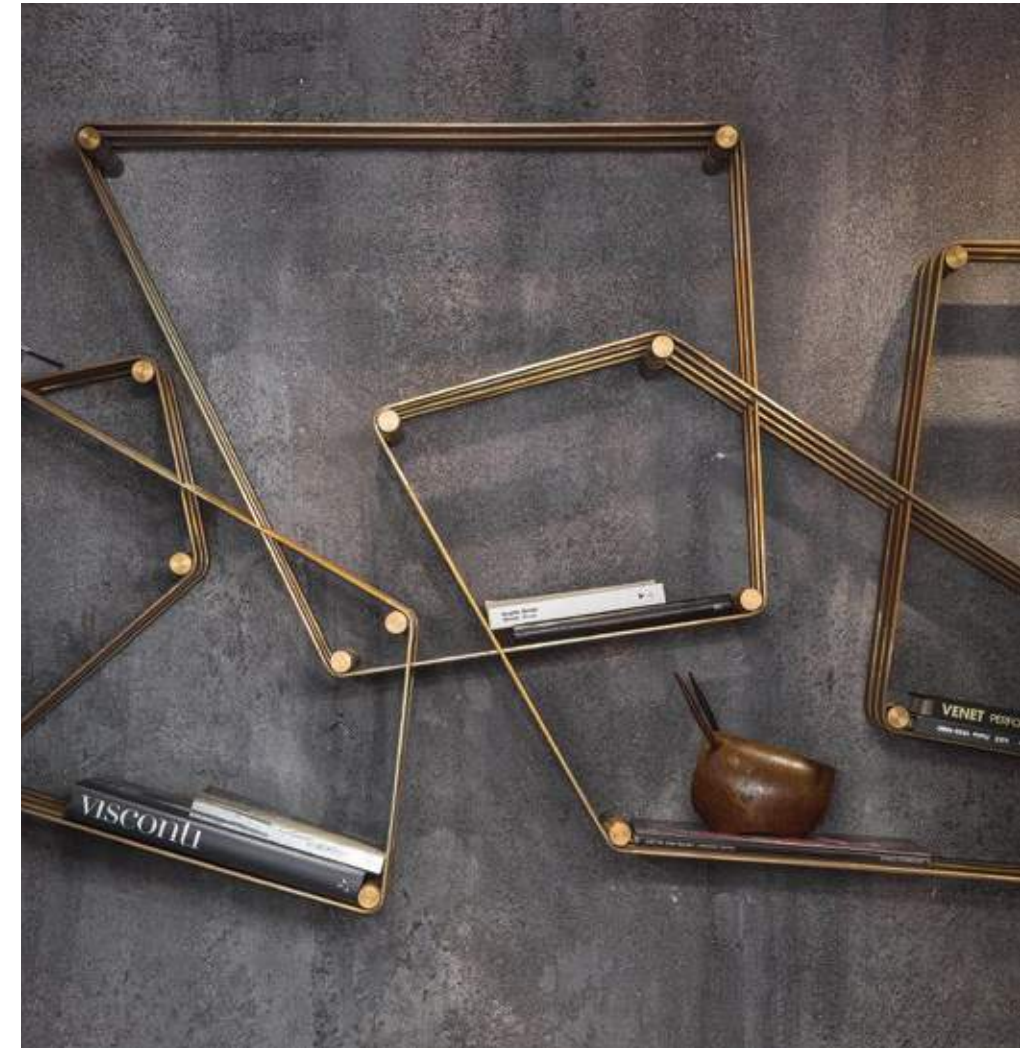

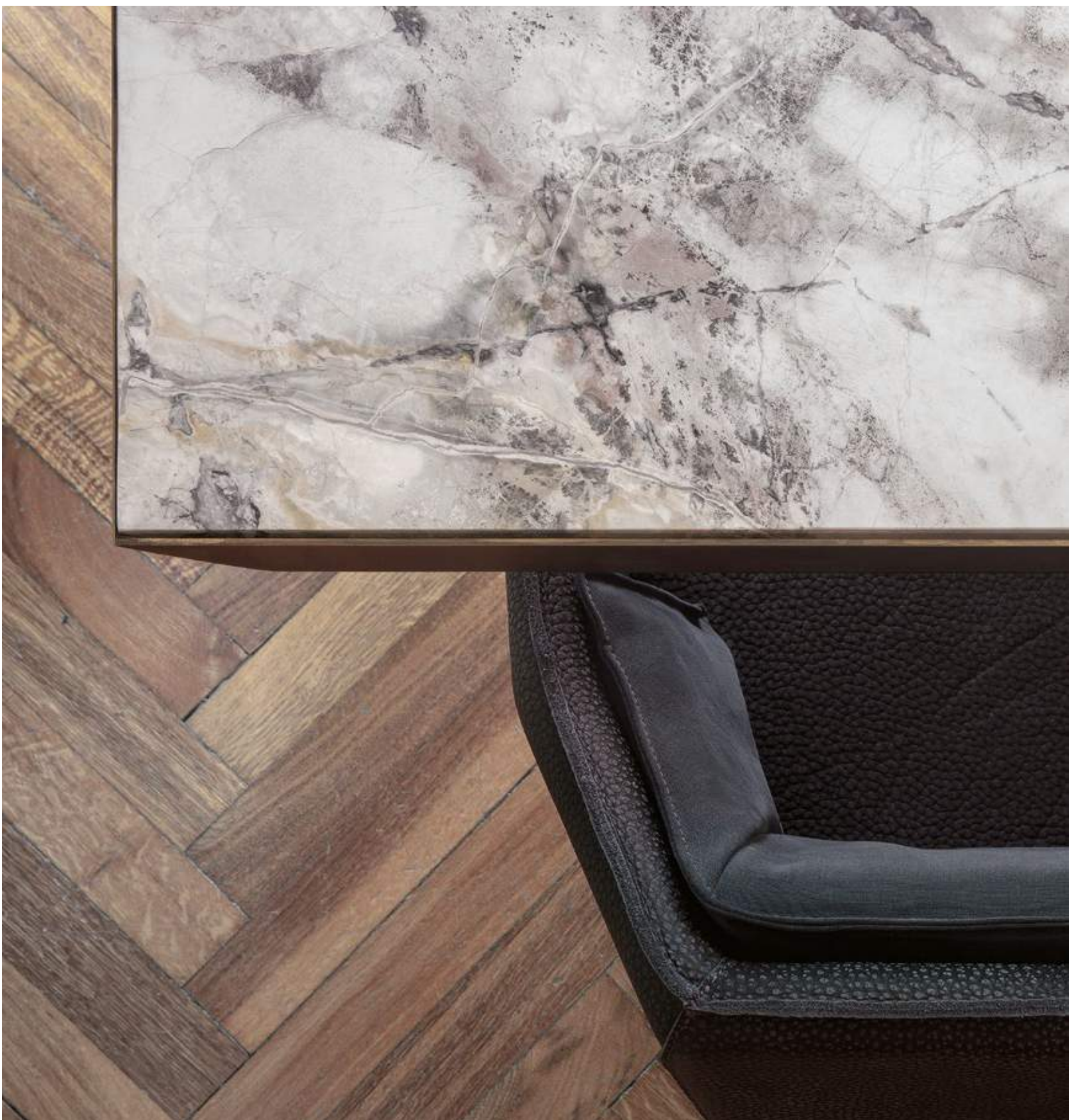

A compositional paradigm combining  
the extreme density of materials steeped  
in expressive power and structures  
that seem to deceive the natural laws  
that keep us anchored to the ground

























## EX-TRA CHAIR

Design Isabella Genovese

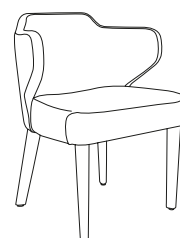

Structure  
Chair with solidwood base and wood legs.  
Cover in the leather samples in the range.  
DIMENSIONS  
62 cm x 60 cm x 80 cm h  
H seat: 45 cm

Sedia con struttura in legno multistrato e gambe in legno.  
Finitura  
Rivestimento nella gamma di pelli a campionario  
DIMENSIONI  
62 cm x 60 cm x 80 cm h  
H seduta: 45 cm

## KETCH CHAIR

Design Massimo Castagna

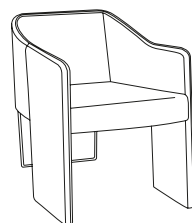

Structure  
Chair with solidwood base, back leg in burnished steel by hand using traditional techniques brass colour finish.  
Finish  
Padded seat, back and arms in leather finish from the samples in the range.  
DIMENSIONS  
60 cm x 52 cm x 75 cm  
H seat 45cm

Struttura  
Sedia con struttura in legno multistrato, telaio posteriore in acciaio brunito finitura ottone a mano secondo le tecniche tradizionali.  
Finitura  
Seduta, schienale e braccioli imbottiti nelle gamma di pelli a campionario.  
DIMENSIONI  
60 cm x 52 cm x 75 cm  
H seduta 45 cm

## STRIP LOUNGE (ARMCHAIR)

Design Massimo Castagna

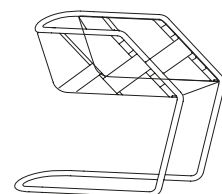

Structure  
Dining chair with Ø 2.5 cm heavy duty curved metal pipe frame.  
Finish  
Burnished steel by hand using traditional techniques  
Burnished brass by hand using traditional techniques.  
Seat padded with woven laser cut double thickness leather Durango, Camoscio, E-Type or Nabuk.  
DIMENSIONS  
58 cm x 60 cm x 61 cm  
H seat 36 cm

Struttura  
Poltroncina con struttura in tubo metallico ad alta resistenza Ø 2.5 cm.  
Finitura  
Acciaio brunito nero, ottone brunito a mano secondo le tecniche tradizionali.  
Seduta imbottita con finitura in pelle Durango, Nabuk, Camoscio ed E-Type intrecciata e lavorata a laser a doppio spessore.  
DIMENSIONI  
58 cm x 60 cm x 61 cm  
H seduta 36 cm

## HUMAN ARMCHAIR

Design Massimo Castagna

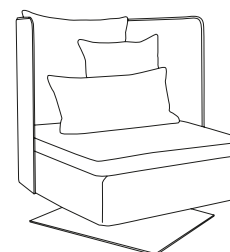

Structure  
Armchair with metal base frame.  
Finish  
The leather samples in the range.  
DIMENSIONS  
80 cm x 75 cm x 90 cm  
H seat 40 cm

Struttura  
Poltroncina con basamento in metallo.  
Finitura  
Nelle gamma di pelli a campionario  
DIMENSIONI  
80 cm x 75 cm x 90 cm  
H seduta 40 cm

## SAETTA TABLE

Design Massimo Castagna

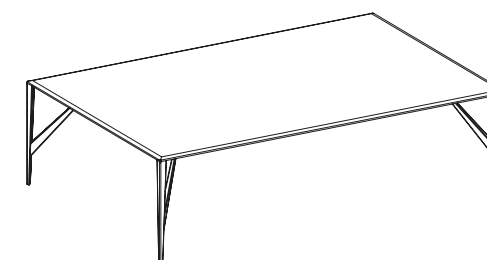

Structure  
Metal pipe.  
Legs  
Legs in sand casting brass and bronze.  
Top  
Marble stones and granites as per our samples.  
DIMENSIONS  
180 cm x 180 cm x 75 cm h  
270 cm x 180 cm x 75 cm h  
Ø 220 x 75 cm h

Struttura  
Tubulare metallo  
Gambe  
In ottone e bronzo con fusione a terra  
Top  
Marmi e graniti nei colori e nelle finiture a campionario  
DIMENSIONI  
180 cm x 180 cm x 75 cm h  
270 cm x 180 cm x 75 cm h  
Ø 220 x 75 cm h

## SHIFT TABLE LOUNGE

Design Massimo Castagna

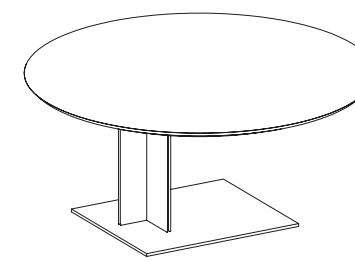

Structure  
Structure in Burnished Black Steel by hand using traditional techniques.  
Top  
Marble stones and granites as per our samples swivelling top.  
DIMENSIONS  
Ø 140 cm x 65 cm h

Struttura  
Struttura in acciaio brunito a mano secondo le tecniche tradizionali  
Top Rotante  
Finiture  
Marmi e graniti nelle finiture a campionario.  
DIMENSIONI  
Ø 140 cm x 65 cm h

Table . Tavolo Ø 140 x 65 H

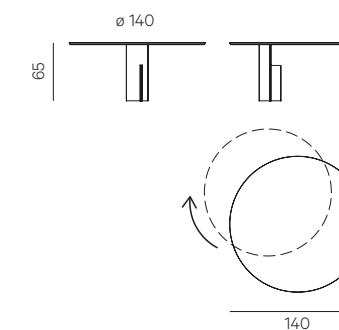



## STEALTH TABLE

Design Massimo Castagna

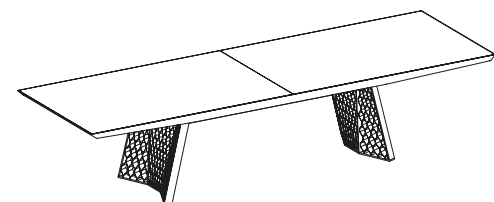

### Structure

Legs, frame and structure in steel burnished by hand brass finish using traditional techniques.

### Top

Heat treated woods as our samples, Swamp Oak, StoneElm® oil finish based on natural wax and water. Marble stones and granites as per our samples.

### DIMENSIONS

270 cm x 110 cm x 75 cm h  
290 cm x 110 cm x 75 cm h  
320 cm x 110 cm x 75 cm h  
345 cm x 110 cm x 75 cm h

### Struttura

Gambe, telaio e cornice in acciaio brunito a mano finitura ottone secondo le tecniche tradizionali.

### Top

Legni termotrattati nelle finiture a campionario, rovere di palude e StoneElm® finiti ad olio a base di cera naturale e acqua. Marmi e graniti nei colori e nelle finiture a campionario.

### DIMENSIONI

270 cm x 110 cm x 75 cm h  
290 cm x 110 cm x 75 cm h  
320 cm x 110 cm x 75 cm h  
345 cm x 110 cm x 75 cm h

## OZONE BAR

Design Massimo Castagna

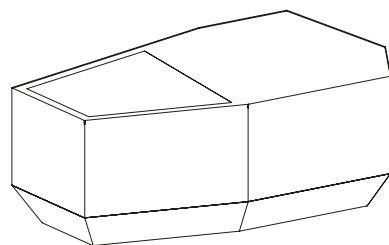

### Structure

Structure and doors in 2 cm thick solidwood.

### Finish

Finish in hand-burnished brass and steel using traditional techniques.

### Stone Top

Stone top, 2 cm thick

### Finish - Top

Marble stones and granites as per our samples.

### DIMENSIONS

150 cm x 150 cm x 91 cm h  
180 cm x 180 cm x 91 cm h  
230 cm x 90 cm x 91 cm h  
245 cm x 140 cm x 91 cm h  
280 cm x 90 cm x 91 cm h

### Struttura

Struttura e ante in legno listellare spessore 2 cm.

### Finitura

Acciaio e ottone brunito a mano secondo le tecniche tradizionali.

Piano in pietra, sp. 2 cm.

Finitura - Piano

Marmi e graniti nei colori e nelle finiture a campionario.

### DIMENSIONI

150 cm x 150 cm x 91 cm h  
180 cm x 180 cm x 91 cm h  
230 cm x 90 cm x 91 cm h  
245 cm x 140 cm x 91 cm h  
280 cm x 90 cm x 91 cm h

## BE-MINE COFFEE TABLE

Design Massimo Castagna

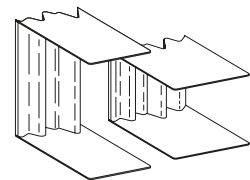

### Structure

Mullion in sand casting brass, base and top in Shine Brass 0,5 cm thick.

### DIMENSIONS

30 cm x 60 cm x 51 cm h  
40 cm x 60 cm x 35 cm h

### Struttura

Struttura in ottone con fusione a terra,

piani in ottone lucido sp. 0,5 cm.

### DIMENSIONI

30 cm x 60 cm x 51 cm h  
40 cm x 60 cm x 35 cm h

## D-CODE TABLE

Design Massimo Castagna

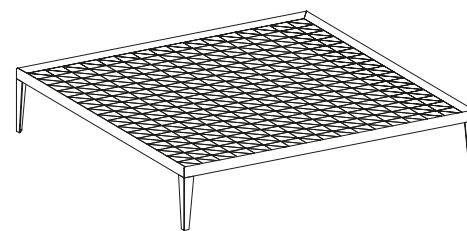

### Structure

Top and legs in Burnished Brass by hand using traditional techniques.

### Top

Burnished Brass by hand using traditional techniques.

### DIMENSIONS

150 cm x 150 cm x 30 cm h

### Struttura

Top e gambe in ottone brunito a mano

secondo le tecniche tradizionali.

### Top

Ottone brunito a mano secondo le tecniche tradizionali.

### DIMENSIONI

150 cm x 150 cm x 30 cm h

## GALAXY MAXI COFFEE TABLE

Design Massimo Castagna

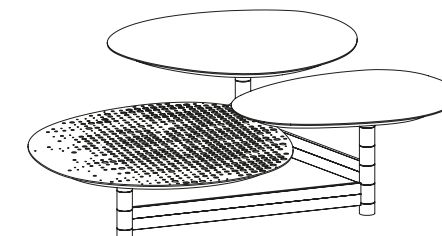

### Structure

Ø 4 cm Brass tube in Burnished Brass by hand using traditional techniques.

Undermounted wood in black matte lacquer, 2 cm thick.

### Top B - C

Heat treated woods as per our samples,

Swamp Oak and Swamp Elm

oil finish based on natural wax and water, Burnished Brass,

Burnished Black Brass by hand using traditional techniques

### Top A - B - C

Burnished Steel by hand using traditional techniques

Burnished Brass by hand using traditional techniques

### DIMENSIONS

160 cm x 150 cm x 39 cm h

### Struttura

Tubolare Ø 4 cm in ottone brunito a mano

secondo le tecniche tradizionali

Sottotop in legno listellare sp. 2 cm

### Top B - C

Legni termotrattati nelle finiture a campionario, rovere

di palude e Swamp Elm finiti ad olio a base di cera

naturale e acqua, ottone brunito e ottone brunito

nero a mano secondo le tecniche tradizionali

### Top A - B - C

Acciaio brunito a mano secondo le tecniche tradizionali

Ottone brunito a mano secondo le tecniche tradizionali

### DIMENSIONI

160 cm x 150 cm x 39 cm h

## MUSHROOM TABLE

Design Yabu Pushelberg

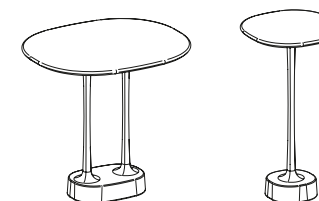

### Structure

Mullion in sand casting brass and bronze.

### DIMENSIONS

32 cm X 32 cm X 60 cm h  
46 cm x 55 cm x 53 cm h

### Struttura

Struttura in ottone e bronzo con fusione a terra.

### DIMENSIONI

32 cm X 32 cm X 60 cm h  
46 cm x 55 cm x 53 cm h

## TOUCH COFFEE TABLE

Design Massimo Castagna

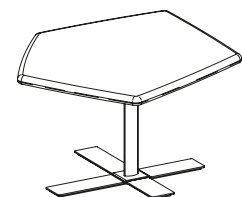

Base  
Burnished Brass by hand using traditional techniques.

Tops  
Oak termowood, 3,3 cm thick

DIMENSIONI

84 cm x 88 cm x 44 cm h  
63 cm x 83 cm x 44 cm h  
48 cm x 107 cm x 44 cm h  
44 cm x 68 cm x 44 cm h  
68 cm x 118 cm x 44 cm h  
93 cm x 94 cm x 44 cm h  
84 cm x 88 cm x 51 cm h  
63 cm x 83 cm x 51 cm h  
48 cm x 107 cm x 51 cm h  
44 cm x 68 cm x 51 cm h  
68 cm x 118 cm x 51 cm h  
93 cm x 94 cm x 51 cm h

Basamento  
Ottone brunito a mano secondo le tecniche tradizionali.

Top  
Rovere termotrattato sp. 3,3 cm.

DIMENSIONI

84 cm x 88 cm x 44 cm h  
63 cm x 83 cm x 44 cm h  
48 cm x 107 cm x 44 cm h  
44 cm x 68 cm x 44 cm h  
68 cm x 118 cm x 44 cm h  
93 cm x 94 cm x 44 cm h  
84 cm x 88 cm x 51 cm h  
63 cm x 83 cm x 51 cm h  
48 cm x 107 cm x 51 cm h  
44 cm x 68 cm x 51 cm h  
68 cm x 118 cm x 51 cm h  
93 cm x 94 cm x 51 cm h

Touch Coffee table h. 51 . A . Girevole

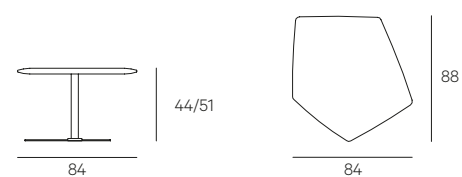

Touch Coffee table h. 51 . B

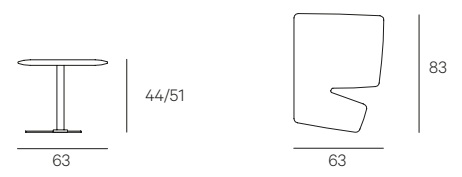

Touch Coffee table h. 51 . C

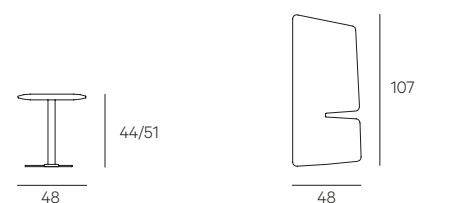

Touch Coffee table h. 51 . D

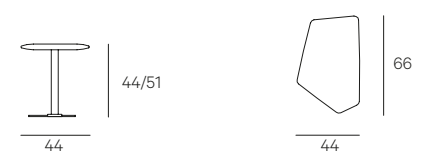

Touch Coffee table h. 51 . E

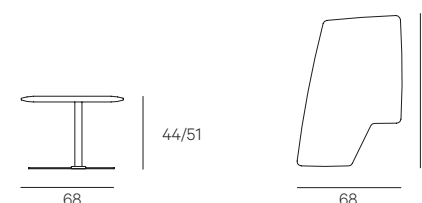

Touch Coffee table h. 51 . F

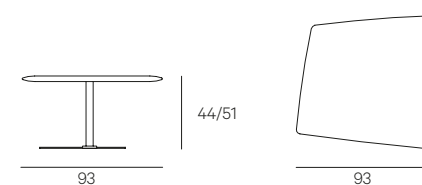

## TOUCH CONSOLE

Design Massimo Castagna

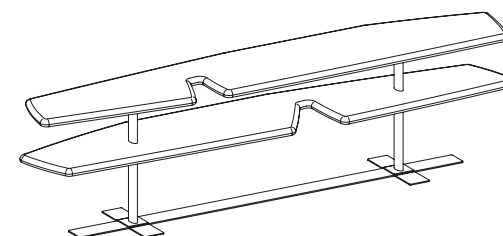

Base  
Burnished Brass by hand using traditional techniques.

Tops  
Oak termowood, 3,3 cm thick.

DIMENSIONI

240 cm x 50 cm x 62 cm h  
300 cm x 50 cm x 62 cm h

Basamento  
Ottone brunito a mano secondo le tecniche tradizionali.

Piano  
Rovere termotrattato sp. 3,3 cm.

DIMENSIONI

240 cm x 50 cm x 62 cm h  
300 cm x 50 cm x 62 cm h

Touch Console 240

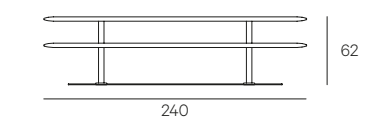

Touch Console 300

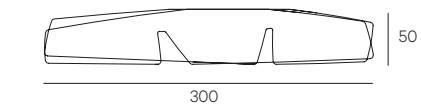
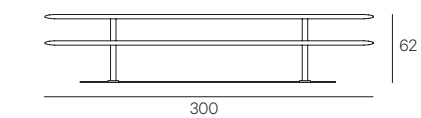

## K-TABLE CONSOLLE

Design Massimo Castagna

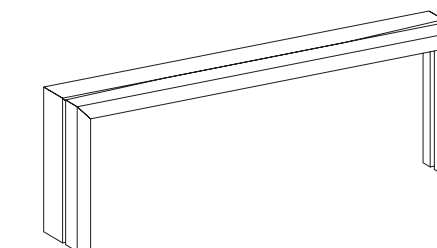

Frame  
Solidwood, 8 cm thick handcrafted at a 45 degree angle.

Finish  
Heat treated woods as per our samples, Swamp Oak and Swamp Elm oil finish based on natural wax and water.

DIMENSIONI

260 cm x 79 cm x 90 cm h

Struttura  
Legno listellare spessore 8 cm lavorato a mano con taglio 45°.

Finitura  
Legni termotrattati nelle finiture a campionario, rovere di palude e Swamp Elm finiti ad olio a base di cera naturale e acqua.

DIMENSIONI

260 cm x 79 cm x 90 cm h

## B-SIDE BUFFET

Design Massimo Castagna

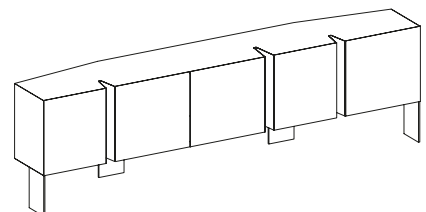

Structure  
Structure and doors 2 cm thick solidwood.  
Glass shelves Stopsol, 1,1 cm thick.  
Finish  
Heat treated woods as our samples, Swamp Oak, StoneElm® oil finish based on natural wax and water.  
V-cut  
V-cut metal finish in Burnished brass by hand using traditional techniques, H-Silver® and Shine Copper.  
Metal Base  
Hand Burnished black by hand using traditional techniques.  
DIMENSIONS  
250 cm x 50 cm x 85 cm h  
300 cm x 50 cm x 85 cm h  
H legs 30cm

Struttura  
Struttura e ante in legno listellare sp. 2 cm.  
Ripiani in vetro Stopsol sp. 1,1 cm.  
Finitura  
Legni termotrattati nelle finiture a campionario, rovere di palude e StoneElm® finiti ad olio a base di cera naturale e acqua.  
Finitura  
Inserti in metallo gola in ottone brunito a mano secondo le tecniche tradizionali, rame lucido e H-Silver®.  
Basamento  
Acciaio brunito nero a mano secondo le tecniche tradizionali.  
DIMENSIONI  
250 cm x 50 cm x 85 cm h  
300 cm x 50 cm x 85 cm h  
H gambe 30cm

## PALAZZI

Design Massimo Castagna

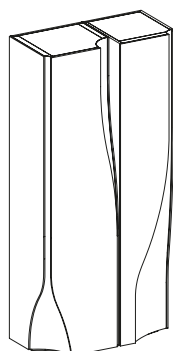

Structure  
Structure and doors in 2 cm thick solidwood.  
Metal, 0,2 cm thick.  
Finish  
Heat treated thermowoods as our samples, Swamp Oak, Swamp Elm oil finish based on natural wax and water.  
Insert in Burnished Brass and H-Silver by hand using traditional techniques.  
DIMENSIONS  
90 cm x 45 cm x 196 cm h

Struttura  
Scocca e ante in legno listellare sp. 2 cm  
Metallo sp. 0,2 cm  
Finitura  
Legni termotrattati nelle finiture a campionario, rovere di palude e Swamp Elm finiti ad olio a base di cera naturale e acqua  
Particolari metallo in ottone e H – Silver brunito a mano secondo le tecniche tradizionali  
DIMENSIONI  
90 cm x 45 cm x 196 cm h

## FRAME CABINET

Design Massimo Castagna

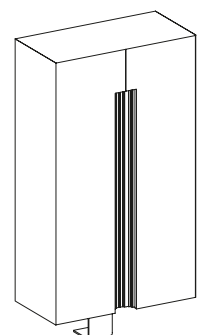

Structure  
Structure and doors in 2 cm thick solidwood  
Frame of the handle in solid heat-treated oak, with closure in Brass, hand-burnished using traditional techniques.  
Brass base, hand-burnished using traditional techniques.  
Included: mandatory wall attachment kit.  
Finish  
Heat treated woods as our samples, Swamp Oak and Swamp Elm oil finish based on natural wax and water.  
Drama Brass, veined hand Burnished Brass by hand using traditional techniques.  
Optional  
1,2 cm thick solidwood trays  
Trays in Brass, hand-burnished using traditional techniques.  
Back in laminated glass 0,3+0,3 cm thick with back-lit inner linen fabric.  
DIMENSIONS  
90 cm x 45 cm x 180 cm h

Struttura  
Scocca e ante in legno listellare spessore 2 cm  
Cornice maniglia in massello di rovere termotrattato con chiusura in ottone brunito a mano secondo le tecniche tradizionali.  
Basamento in acciaio finitura ottone brunito a mano secondo le tecniche tradizionali.  
Di serie: kit per il fissaggio a muro obbligatorio.  
Finitura  
Legni termotrattati nelle finiture a campionario, rovere di palude e Swamp Elm finiti ad olio a base di cera naturale e acqua.  
Drama ottone, ottone brunito fiammato a mano secondo le tecniche tradizionali.  
Optional  
Vassoi in legno listellare sp 1,2 cm  
Vassoi in ottone brunito a mano secondo le tecniche tradizionali.  
Schienale sp. 0,3+0,3 cm in vetro garzato retroilluminato.  
DIMENSIONI  
90 cm x 45 cm x 180 cm h

## LOOM FR

Design Massimo Castagna

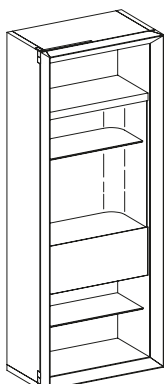

Structure  
Solidwood, thickness 4 cm.  
Frame  
Frame in Brass and steel. Finish in Burnished Brass, Burnished black steel by hand using traditional techniques.  
Storage units with flap doors  
Solidwood, thickness 2 cm. Heat treated woods as our samples and Swamp Oak oil finish based on natural wax and water.  
Optional finish: Burnished Black Brass, Burnished Brass, Burnished black steel by hand using traditional techniques.  
Shelves  
Stopsol glass, 1,1 cm thick.  
DIMENSIONS  
86 cm x 55 cm x 234 cm h

Scocca  
Legno listellare spessore 4 cm.  
Cornice  
Cornice in ottone o acciaio, finitura ottone brunito, acciaio brunito nero a mano secondo le tecniche tradizionali.  
Contentore a ribalta  
Struttura in Legno listellare spessore 2 cm. Legni termotrattati nelle finiture a campionario e rovere di palude, finiti ad olio a base di cera naturale e acqua.  
Optional: Ottone brunito, ottone brunito nero a mano secondo le tecniche tradizionali.  
Mensole  
Vetro Stopsol sp. 1,1cm  
DIMENSIONI  
86 cm x 55 cm x 234 cm h

## LOOM SYSTEM

Design Massimo Castagna

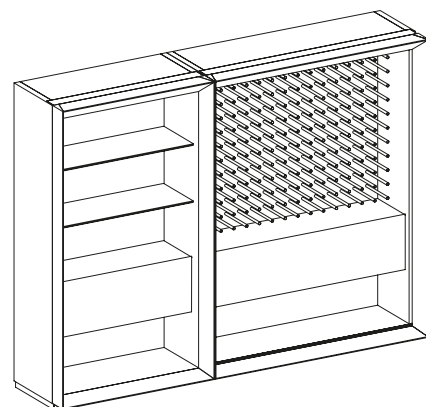

Structure  
Solidwood, thickness 4 cm, base 4cm h.  
Finish  
Heat treated woods as our samples, Swamp Oak and StoneElm® oil finish based on natural wax and water.  
Frame  
Frame in burnished black steel and burnished brass by hand using traditional techniques.  
Backrest  
Heat treated woods as our samples, Swamp Oak and SwampElm® oil finish based on natural wax and water with bottle handlers Ø 0,15 cm in black burnished steel, burnished brass and black burnished brass by hand using traditional techniques.  
Titanium stone.  
Storage units with flap doors  
Structure in solidwood, thickness 2 cm.  
Glass shelves Stopsol 1,1 cm thick.  
Finish  
Heat treated woods as our samples, Swamp Oak and SwampElm® oil finish based on natural wax and water with bottle handlers in burnished black steel, burnished brass, burnished black brass, by hand using traditional techniques and scratched brass.  
Optional  
Lights led kit lighting switch system.  
DIMENSIONS  
100 cm x 55 cm x 184 cm h  
120 cm x 55 cm x 184 cm h  
140 cm x 55 cm x 184 cm h

Struttura  
Legno listellare sp. 4 cm, zoccolo h. 4 cm  
Finitura  
Legni termotrattati nelle finiture a campionario, rovere di palude e StoneElm® finiti ad olio a base di cera naturale e acqua.  
Cornice  
Cornice in acciaio brunito nero e ottone brunito a mano secondo le tecniche tradizionali.  
Schienale  
Legni termotrattati nelle finiture a campionario, rovere di palude finiti ad olio a base di cera naturale e acqua con supporti portabottiglie Ø 0,15 cm in acciaio brunito nero, ottone brunito e ottone brunito nero a mano secondo le tecniche tradizionali.  
Pietra Titanium.  
Contentori a ribalta  
Struttura in legno listellare sp. 2 cm.  
Ripiani in vetro Stopsol sp. 1,1 cm.  
Finitura  
Legni termotrattati nelle finiture a campionario, rovere di palude e SwampElm® finiti ad olio a base di cera naturale e acqua con supporti portabottiglie in acciaio brunito nero, ottone brunito, ottone brunito nero a mano secondo le tecniche tradizionali e ottone graffiato.  
Optional  
Illuminazione strisce led, accensione con interruttore.  
DIMENSIONI  
100 cm x 55 cm x 184 cm h  
120 cm x 55 cm x 184 cm h  
140 cm x 55 cm x 184 cm h

## STILE SET

Design Massimo Castagna

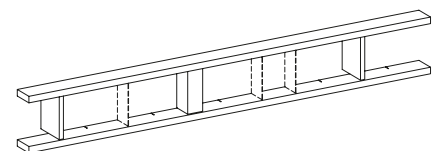

### Structure

Structure in 3,6 cm thick solidwood.

Uprights in 2,5 cm thick solidwood

### Finish

Heat treated woods as our samples and Swamp Oak, Swamp Elm oil finish based on natural wax and water.

### Internal Partitions

3 mm solid metal in Burnished Brass, Burnished Black Brass

Burnished black steel, Scratched Brass, by hand using traditional techniques. H-Silver, Scratched H-Silver\*,

Shine Brass, Shine copper.

9 cm solidwood folded with metal in Burnished Brass,

Burnished Black Brass, Burnished black steel, Scratched

Brass, by hand using traditional techniques. H-Silver,

Scratched H-Silver\*, Shine Brass, Shine copper.

### Wall Light Kit

Sidelight top-bottom, cover in Burnished Brass,

Burnished Black Brass, Burnished black steel, Scratched

Brass, by hand using traditional techniques. H-Silver,

Scratched H-Silver\*, Shine Brass, Shine copper.

160 cm led 3000 k 2,968 Lm 34 W

240 cm led 3000 k 4,180 Lm 52 W

### DIMENSIONS

160 cm x 20 x 25 cm h (Standard internal

partitions n.1 of 0,3 cm and n.1 of 9 cm)

160 cm x 20 x 31 cm h (Standard internal

partitions n.1 of 0,3 cm and n.1 of 9 cm)

160 cm x 20 x 43 cm h (Standard internal

partitions n.1 of 0,3 cm and n.1 of 9 cm)

240 cm x 20 x 25 cm h (Standard internal

partitions n.2 of 0,3 cm and n.1 of 9 cm)

240 cm x 20 x 31 cm h (Standard internal

partitions n.2 of 0,3 cm and n.1 of 9 cm)

240 cm x 20 x 43 cm h (Standard internal

partitions n.2 of 0,3 cm and n.1 of 9 cm)

Sizes can be customized

### Struttura

Struttura in legno listellare sp. 3,6 cm, montanti

in legno listellare sp. 2,5 cm.

### Finitura

Legni termotrattati nelle finiture a campionario, rovere di palude

e Swamp Elm finiti ad olio a base di cera naturale e acqua.

### Divisori interni

Acciaio brunito nero, ottone brunito a mano secondo le tecniche

tradizionali, ottone graffiato, H-Silver, H-Silver\* graffiato, ottone

lucido e rame lucido sp. 0,3 cm. Legno listellare rivestito in

Acciaio brunito nero, ottone brunito, ottone brunito nero a

mano secondo le tecniche tradizionali, ottone graffiato, H-Silver,

H-Silver\* graffiato, ottone lucido e rame lucido sp. 9 cm.

### Wall light kit

Luce radente alto-basso, copertura in Acciaio brunito

nero, ottone brunito, ottone brunito nero a mano

secondo le tecniche tradizionali, ottone graffiato, H-Silver,

H-Silver\* graffiato, ottone lucido e rame lucido.

### DIMENSIONI

160 cm x 20 cm x 25 cm h (divisori di serie

n. 1 da 0,3 cm e n. 1 da 9 cm)

160 cm x 20 cm x 31 cm h (divisori di serie

n. 1 da 0,3 cm e n. 1 da 9 cm)

160 cm x 20 cm x 43 cm h (divisori di serie

n. 1 da 0,3 cm e n. 1 da 9 cm)

240 cm x 20 cm x 25 cm h (divisori di serie

n. 2 da 0,3 cm e n. 1 da 9 cm)

240 cm x 20 cm x 31 cm h (divisori di serie

n. 2 da 0,3 cm e n. 1 da 9 cm)

240 cm x 20 cm x 43 cm h (divisori di serie

n. 2 da 0,3 cm e n. 1 da 9 cm)

Personalizzabile a disegno

### Bookshelf . Libreria cm 160

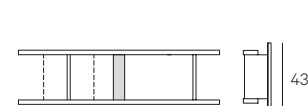
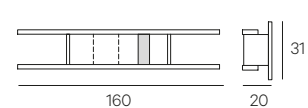
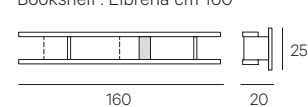

### Bookshelf . Libreria cm 240

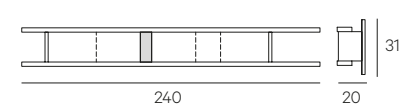
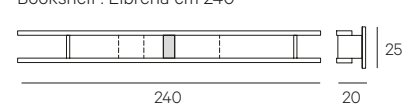

### Wall Light Kit . Kit Luci a parete

L. 160, 240 cm x 15 cm h

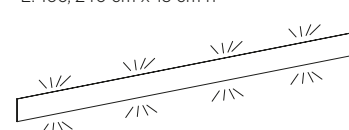

## CAGE-B S

Design Massimo Castagna

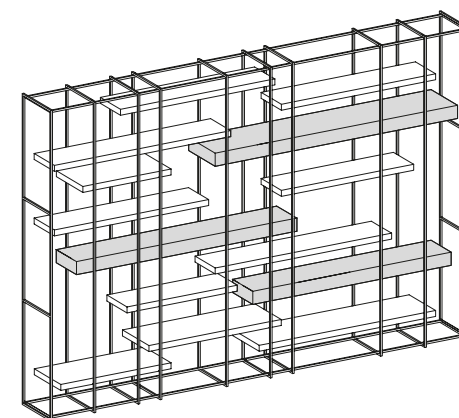

### Metal frame bookshelf

#### Structure

Square solid steel uprights, 1,5 x 1,5 cm, steel shelf supports.

Square Brass pipe uprights, 1,5 x 1,5 cm, Brass shelf supports.

#### Structure Finish

Black steel hand-burnished using traditional techniques.

Brass hand-burnished using traditional techniques.

#### Shelves

5 cm thick solidwood.

10 cm thick metal.

#### Shelves Finish

Heat treated woods as our samples, Swamp Oak and

Swamp Elm oil finish based on natural wax and water.

Burnished Steel and Busnished Brass by

hand using traditional techniques.

SIZES CAN BE CUSTOMIZED

### Libreria in metallo con ripiani

#### Struttura

Montanti in acciaio quadro pieno 1,5 x 1,5 cm,

supporti ripiani in acciaio. Montanti in ottone quadro

tubolare 1,5 x 1,5 cm, supporti ripiani in ottone.

#### Finitura Struttura

Acciaio brunito nero a mano secondo le tecniche tradizionali.

Verniciato nei colori rosso minio o tortora. Ottone brunito

a mano secondo le tecniche tradizionali.

#### Ripiani

Legno listellare spessore 5 cm.

Metallo spessore 10 cm.

#### Finitura Ripiani

Legni termotrattati nelle finiture a campionario, rovere

di palude e Swamp Elm finiti ad olio a

base di cera naturale e acqua.

Acciaio e ottone brunito a mano secondo

le tecniche tradizionali.

PERSONALIZZABILE A DISEGNO

### Bookshelf . Libreria 180x35x260

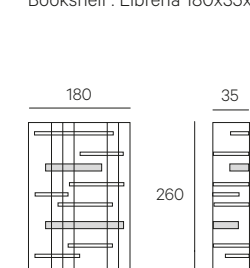

### Bookshelf . Libreria 240x35x260

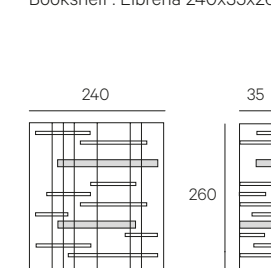

### Bookshelf . Libreria 180x45x260

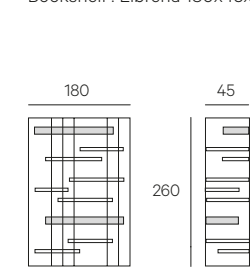

### Bookshelf . Libreria 240x45x260

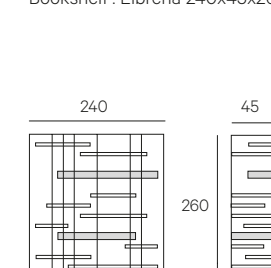

## BISTROT

Design Massimo Castagna

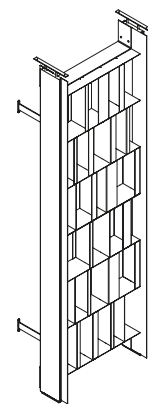

### Structure

Upright structure in 2,2 cm thick solidwood covered in burnished brass by hand using traditional techniques. Base and wall support in black burnished steel using traditional techniques.

Internal structure 0,2 cm thick in hand-burnished brass using traditional techniques.

### DIMENSIONS

70 cm x 24 x 270 cm h

### Struttura

Struttura esterna in legno listellare sp. 2,2 cm rivestita in ottone brunito e ottone brunito nero a mano secondo le tecniche tradizionali. Piedini, supporti a muro e ponte di unione in acciaio brunito nero a mano secondo le tecniche tradizionali.

Struttura interna in ottone brunito a mano secondo le tecniche tradizionali sp. 0,2 cm

### DIMENSIONI

70 cm x 24 cm x 270 cm h

## BISTROT S

Design Massimo Castagna

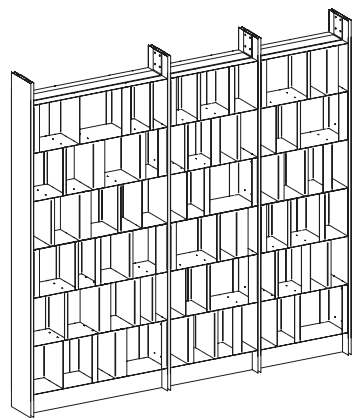

### Structure

External columns in 2,5 cm thick solidwood covered in Burnished Brass by hand using traditional techniques. Base and wall support in black burnished steel using traditional techniques.

### DIMENSIONS

200 cm x 29 x 270 cm h

240 cm x 29 x 270 cm h

280 cm x 29 x 270 cm h

320 cm x 29 x 270 cm h

### Struttura

Struttura esterna il legno listellare sp. 2,5 rivestita in ottone brunito a mano secondo le tecniche tradizionali. Piedini e ponte di unione in acciaio brunito nero a mano secondo le tecniche tradizionali.

### DIMENSIONI

200 cm x 29 x 270 cm h

240 cm x 29 x 270 cm h

280 cm x 29 x 270 cm h

320 cm x 29 x 270 cm h

### Bookshelf . Libreria 280 x 29 x 270 H

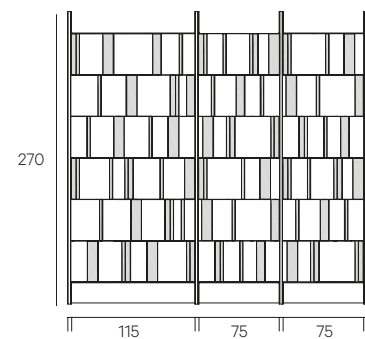

### Bookshelf . Libreria 320 x 29 x 270 H

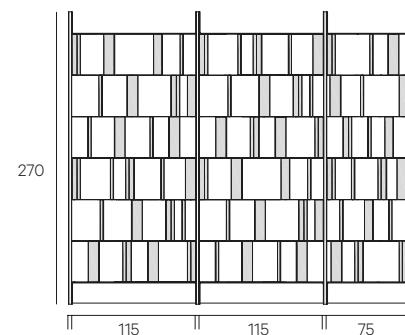

## MYST DAY BED

Design Massimo Castagna

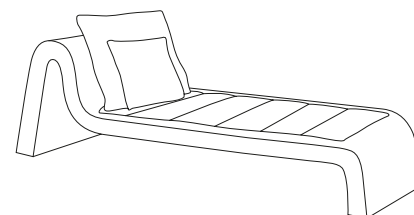

### Structure

Solidwood base

### Cover

Range of leathers and Nappa leather as per sample,

### DIMENSIONS

215 cm x 70 cm x 68 cm h

### Struttura

Legno multistrato

Rivestimenti

Gamma pelli e nappa a campionario.

### DIMENSIONI

215 cm x 70 cm x 68 cm h

## RADICAL SOFA

Design Massimo Castagna

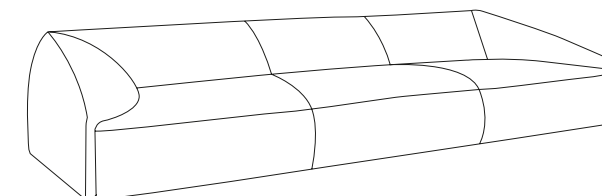

### Structure

Norwegian conifer solidwood.

### Seat

Padding 75% white feather + 25% polyester fiber

Polyurethane foam D/35 last PFFR density 35/m<sup>3</sup>, lift 2,3 kPa

Anti-feather lining 100% white cotton.

### Back

Padding 75% white feather.

Polyurethane foam D/35 last PFFR density 35/m<sup>3</sup>, lift 3,6 kPa

Infill polyurethane foam D/40 P density 40 Kg/m<sup>3</sup> lift 8 KPA

Anti-feather lining 100% white cotton.

### Base

8x8x5 h cm black varnished wood .

### Upholstery

Leathers and fabrics range as per our samples, additional cushions and decoratives in leathers or fabrics as per our samples.

### DIMENSIONS

260/290/320x110x70 h

Seat 41 h

### Struttura

Listellare di conifera norvegese.

### Seduta

Imbottitura 75% piuma bianca + 25% fibra poliestere

Sedile poliuretano espanso D/35 elast PFFR densità 35/m<sup>3</sup>, portanza 2,3 kPa. Rivestimento antipiuma 100% cotone bianco.

### Schienale

Imbottitura 75% piuma bianca.

Schienale poliuretano espanso D/35 EM densità 35/m<sup>3</sup>, portanza

3,6 kPa. Tamponamenti poliuretano espanso D/40 P densità 40 Kg/

m<sup>3</sup> portanza 8 KPa . Rivestimento antipiuma 100% cotone bianco.

### Piedini

Mis. 8x8x5 h cm legno verniciato nero.

### Rivestimenti

Gamma pelli e nappa a campionario, cuscinate

aggiuntive e decorative in pelle e nappa o nei

tessuti delle collezioni a campionario.

### DIMENSIONI

260/290/320x110x70 h

Seduta 41 h

### Radical Sofa 260 mm

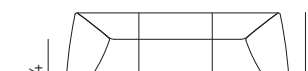
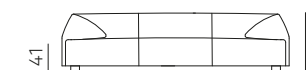

### Radical Sofa 290 mm

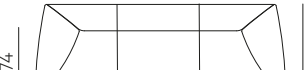
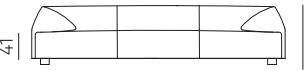

### Radical Sofa 320 mm

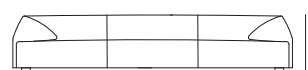

320

# PULSE SOFA

Design Massimo Castagna

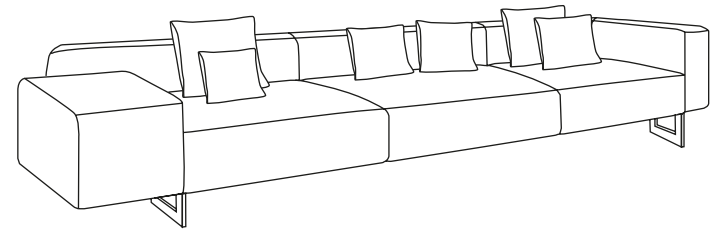

## Structure

Norwegian conifer solidwood

## Seat

Padding 75% white feather + 25% polyester fiber  
Polyurethane foam D/35 last PFFR density 35/m<sup>3</sup>, lift 2.3 kPa  
Anti-feather lining 100% white cotton

## Back

Padding 75% white feather  
Polyurethane foam D/35 last PFFR density 35/m<sup>3</sup>, lift 3.6 kPa  
Infill polyurethane foam D/40 P density 40 Kg/m<sup>3</sup> lift 8 KPA  
Anti-feather lining 100% white cotton

## Base

Burnished Steel by hand using traditional techniques in Brass color.

## Upholstery

Leathers and fabrics range as per our samples, additional cushions and decoratives in leathers or fabrics as per our samples

## DIMENSIONS

102x70 h

Seat 43 h

## Struttura

Listellare di conifera norvegese.

## Seduta

Imbottitura 75% piuma bianca + 25% fibra poliestere  
Sedile poliuretano espanso D/35 elast PFFR densità 35/m<sup>3</sup>, portanza 2.3 kPa.

Rivestimento antipiùma 100% cotone bianco

## Schienale

Imbottitura 75% piuma bianca  
Schienale poliuretano espanso D/35 EM densità 35/m<sup>3</sup>, portanza 3.6 kPa. Tamponamenti poliuretano espanso D/40 P densità 40 Kg/m<sup>3</sup> portanza 8 KPa.

Rivestimento antipiùma 100% cotone bianco.

## Basamento

Acciaio brunito a mano finitura ottone

secondo le tecniche tradizionali

## Rivestimenti

Gamma pelli, nappa e tessuti a campionario, cuscinate aggiuntive e decorative in pelle e nappa o nei tessuti delle collezioni a campionario.

## DIMENSIONI

102x70 h

Seduta 43 h

Terminal element with armrest Rh - 90  
Elemento terminale con bracciolo Dx - 90

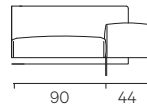

Terminal element with armrest Lh - 90  
Elemento terminale con bracciolo Sx - 90

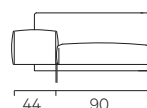

Terminal element with armrest Rh - 110  
Elemento terminale con bracciolo Dx - 110

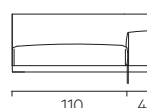

Terminal element with armrest Lh - 110  
Elemento terminale con bracciolo Sx - 110

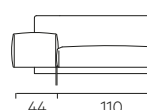

Terminal element with armrest Rh - 130  
Elemento terminale con bracciolo Dx - 130

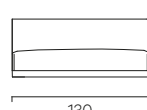

Terminal element with armrest Lh - 130  
Elemento terminale con bracciolo Sx - 130



Terminal element with armrest Rh - 90  
Elemento terminale con bracciolo Dx - 90

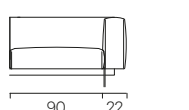

Terminal element with armrest Lh - 90  
Elemento terminale con bracciolo Sx - 90

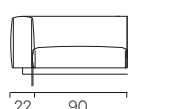

Terminal element with armrest Rh - 110  
Elemento terminale con bracciolo Dx - 110



Terminal element with armrest Lh - 110  
Elemento terminale con bracciolo Sx - 110

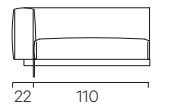

Terminal element with armrest Rh - 132  
backrest 154  
Elemento terminale con bracciolo Dx - 132  
con schienale da 154

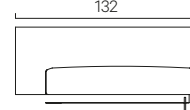

Terminal element with armrest Lh - 132  
backrest 154  
Elemento terminale con bracciolo Sx - 132  
con schienale da 154



Terminal element with armrest Rh - 130  
Elemento terminale con bracciolo Dx - 130

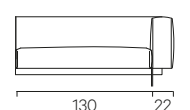

Terminal element with armrest Lh - 130  
Elemento terminale con bracciolo Sx - 130

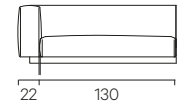

Central element - 90  
Elemento centrale - 90

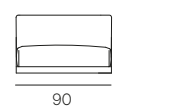

Central element - 110  
Elemento centrale - 110

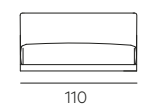

Central element - 130  
Elemento centrale - 130

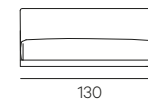

Low meridien 110 Rh backrest 90  
Penisola bassa da 110 Dx con schienale da 90

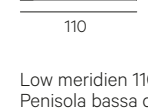
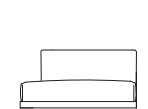

Low meridien 110 Lh backrest 90  
Penisola bassa da 110 Sx con schienale da 90

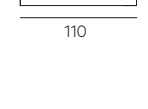
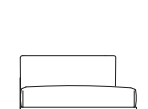

Low meridien 130 Rx backrest 110  
Penisola bassa da 130 Dx con schienale da 110

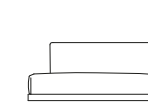

Low meridien 130 Rx backrest 110  
Penisola bassa da 130 Sx con schienale da 110

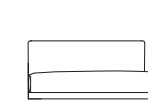

Backrest cushion . Cuscino schienale

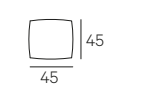

Backrest cushion . Cuscino schienale

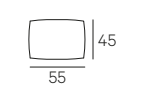

Backrest cushion . Cuscino schienale

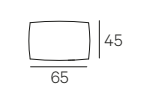

Backrest cushion . Cuscino schienale

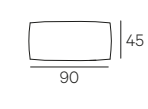

Backrest cushion . Cuscino schienale

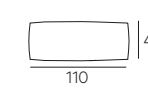

Backrest cushion . Cuscino schienale

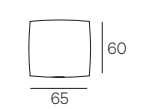

Backrest cushion . Cuscino schienale

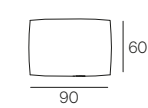

PULSE SOFA

# Composition 01

- 01. H-Silk Carpet
- 02. Be-Mine Coffee Table
- 03. Touch Coffee Table
- 04. W-Table
- 05. Human Armchair
- 06. R-Table

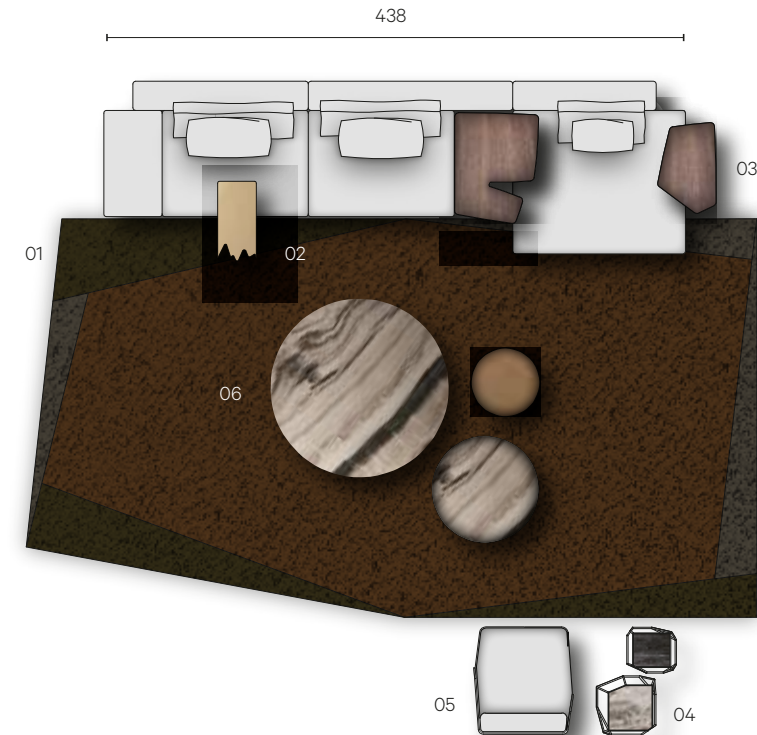

PULSE SOFA

# Composition 03

- 01. H-Silk Carpet
- 02. Be-Mine Coffee Table
- 03. Touch Coffee Table
- 04. W-Table
- 05. Human Armchair
- 06. Mushroom Coffee Table
- 07. Myst Day Bed
- 08. D-Code Table

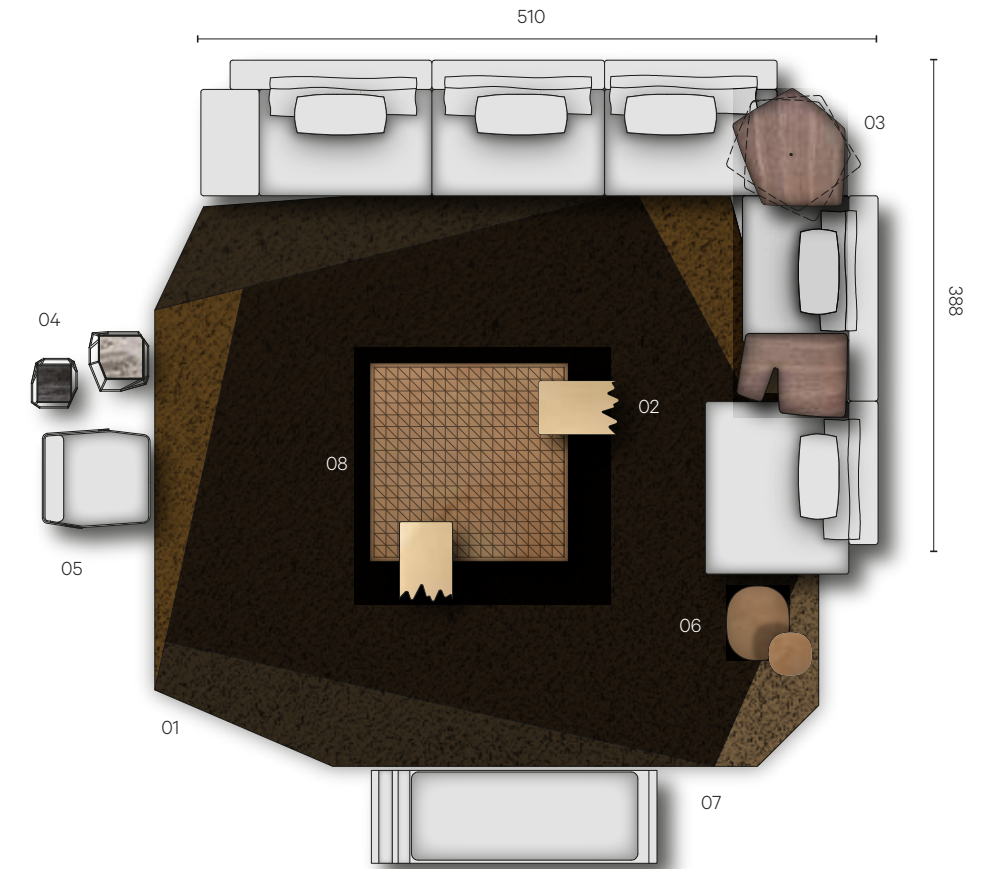

PULSE SOFA

# Composition 02

- 01. H-Silk Carpet
- 02. OR Table
- 03. Touch Coffee Table
- 04. W-Table
- 05. Ketch Armchair
- 06. Octagon Table
- 07. Myst Day Bed

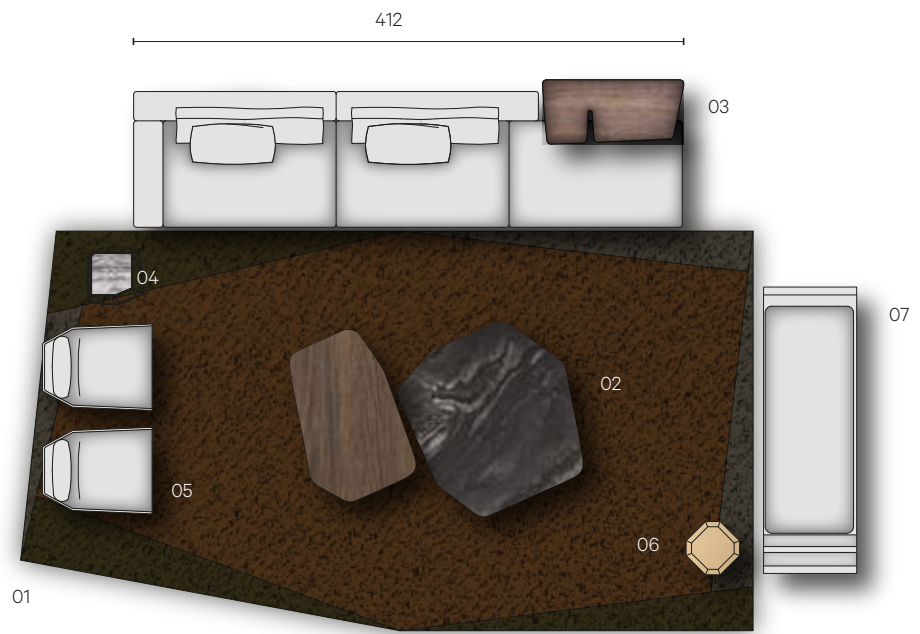

PULSE SOFA

# Composition 04

- 01. H-Silk Carpet
- 02. Be-Mine Coffee Table
- 03. Touch Coffee Table
- 04. W-Table
- 05. Echo Armchair
- 06. Shift Table
- 07. D-Code Table
- 08. Strip Lounge Armchair

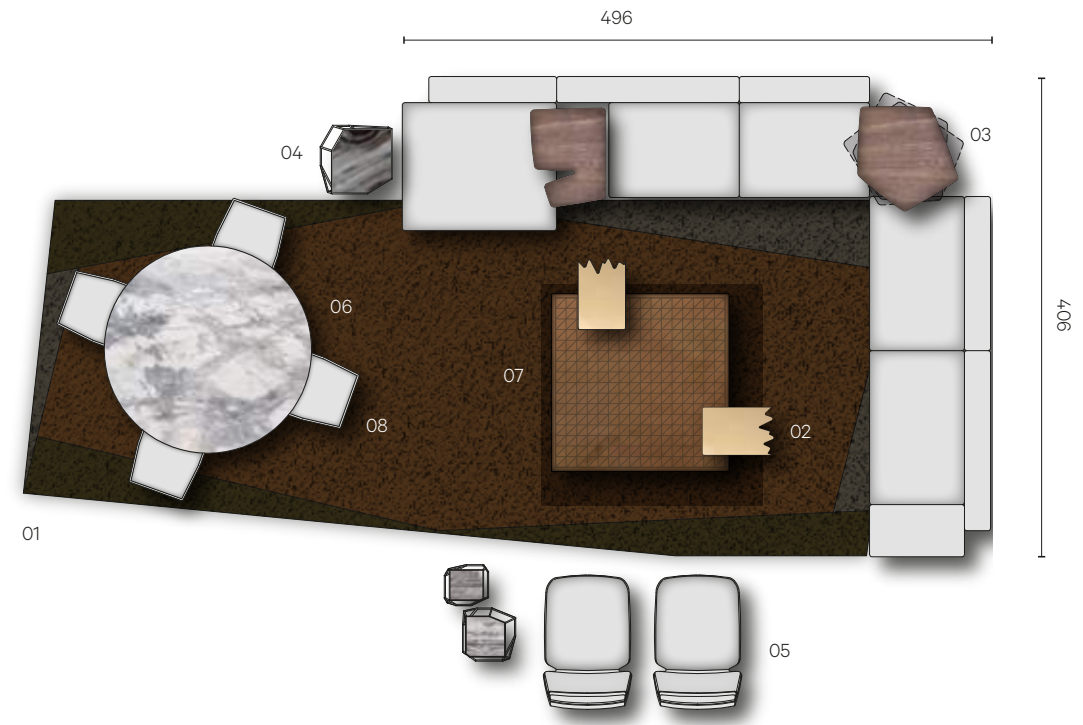

# HUMAN SOFA

Design Massimo Castagna

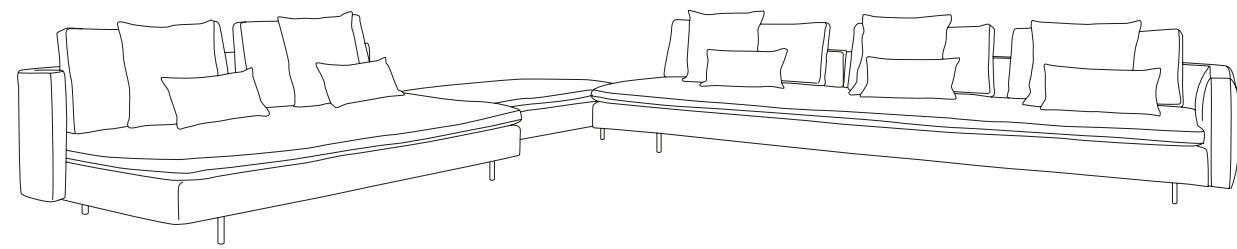

## Structure

Norwegian softwood solidwood.

## Padding

280 gr Tecnoform jet backed with 200 gr resin sheet. Backrest cushions and arms cushions padded in D/21 SM. Polyurethane foam backed with 200 gr resin sheet and down feather. Seat with under-seat in D/30 E polyurethane foam, seat top in D/30 EET polyurethane foam, covered with a pad in D/40 PF polyurethane foam, seat front with 300 gr lap strip. Edge to edge seams on leather and nappa upholstery.

## Upholstery

Leather or nappa from our range, additional and decorative cushions in leather or nappa from our range, or in natural fabrics from the collections. The fabric version as a perimetric lap-felled seam.

## DIMENSIONS

105 cm x 78 cm h  
105 cm x 68 cm h

## Struttura

Listellare di conifera norvegese.

## Imbottitura

Tecnoform jet 280 gr accoppiato a resinato 200 gr. Imbottitura di cuscini schienale e bracciolo realizzati in poliuretano espanso D/21 SM. Rivestimento tecnoform jet 280 gr accoppiato a resinato 200 gr e piuma. Seduta con sotto sedile realizzato in poliuretano espanso D/30 E, sopra sedile realizzato in poliuretano espanso D/30 EET, tampone sopra seduta realizzato in poliuretano espanso D/40 PF, frontale seduta fascia falda 300 gr. Pelle e nappa di rivestimento in finitura a taglio vivo.

## Rivestimenti

Gamma pelli, nappa e tessuti a campionario, cuscinate aggiuntive e decorative in pelle e nappa a campionario o nei tessuti naturali delle collezioni a campionario. La versione in tessuto ha la cucitura con ribattuta perimetrale.

## DIMENSIONI

105 cm x 78 cm h  
105 cm x 68 cm h

Element 90 LH . LOW

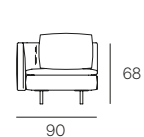

Element 90 RH . LOW

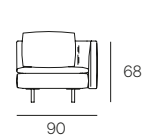

Element 160 LH . LOW

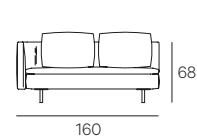

Element 160 RH . LOW

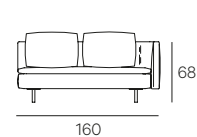

Element 230 LH . LOW

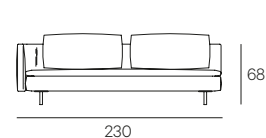

Element 230 RH . LOW

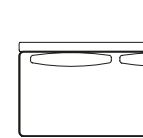
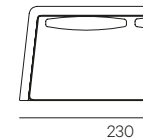
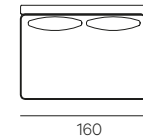
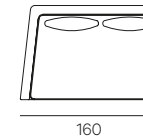
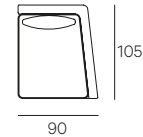
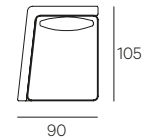
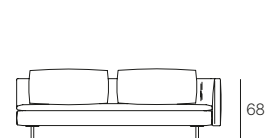

Central element 70 . HIGH

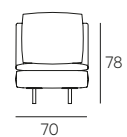

Central element 140 . HIGH

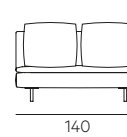

Central element 210 . HIGH

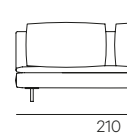

Central element 70 . LOW

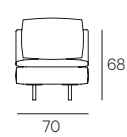

Central element 140 . LOW

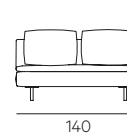

Central element 210 . LOW

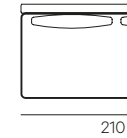
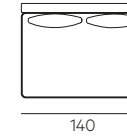
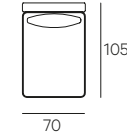
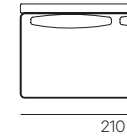
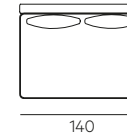
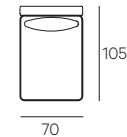
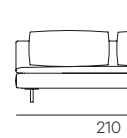

Pouf 70 x 95

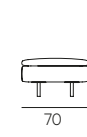

Pouf 140 x 95

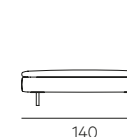

Chaise long LH 90 x 175 . HIGH

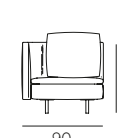

Chaise long RH 90 x 175 . HIGH

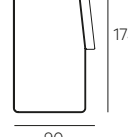
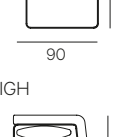
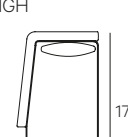
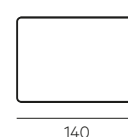
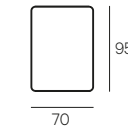
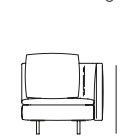

Loose cushion . Cuscinello 60x30

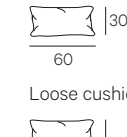

Loose cushion . Cuscinello 60x60

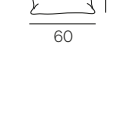



HUMAN SOFA

# Composition 01

- 01. H-Silk Carpet
- 02. D-Code Coffe Table
- 03. Touch Coffee Table
- 04. W-Table
- 05. Human Armchair
- 06. Octagon Table
- 07. Myst Day Bed

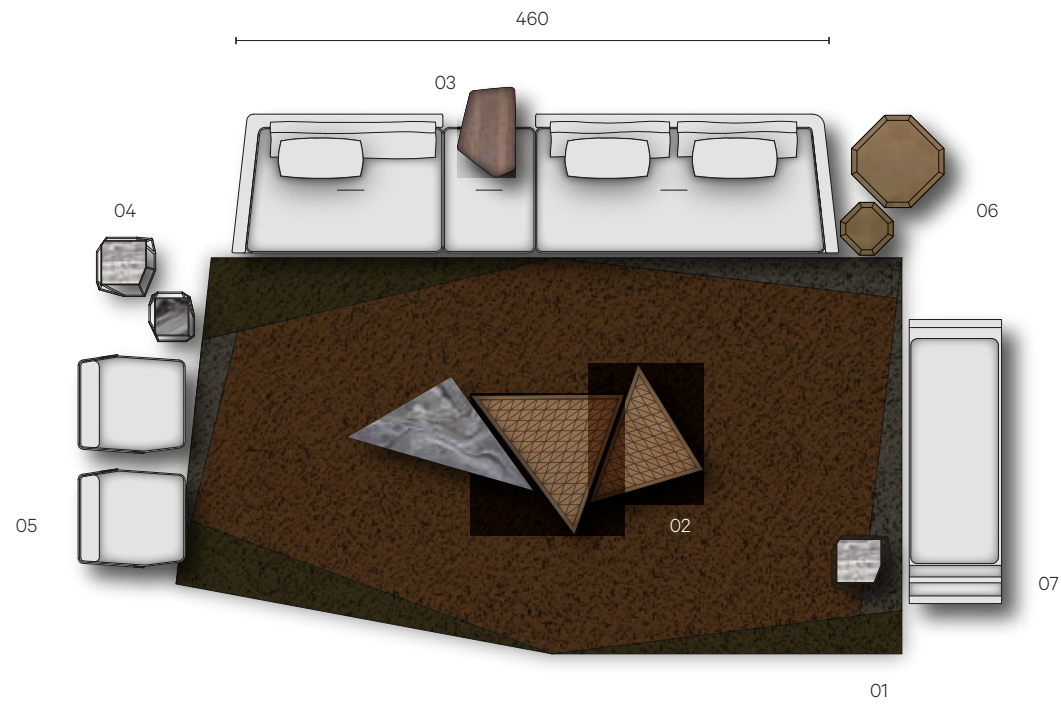

HUMAN SOFA

# Composition 03

- 01. H-Silk Carpet
- 02. Be-Mine Coffee Table
- 03. Touch Coffee Table
- 04. Octagon Table
- 05. Human Armchair
- 06. Mushroom Coffe Table
- 07. D-Code Table

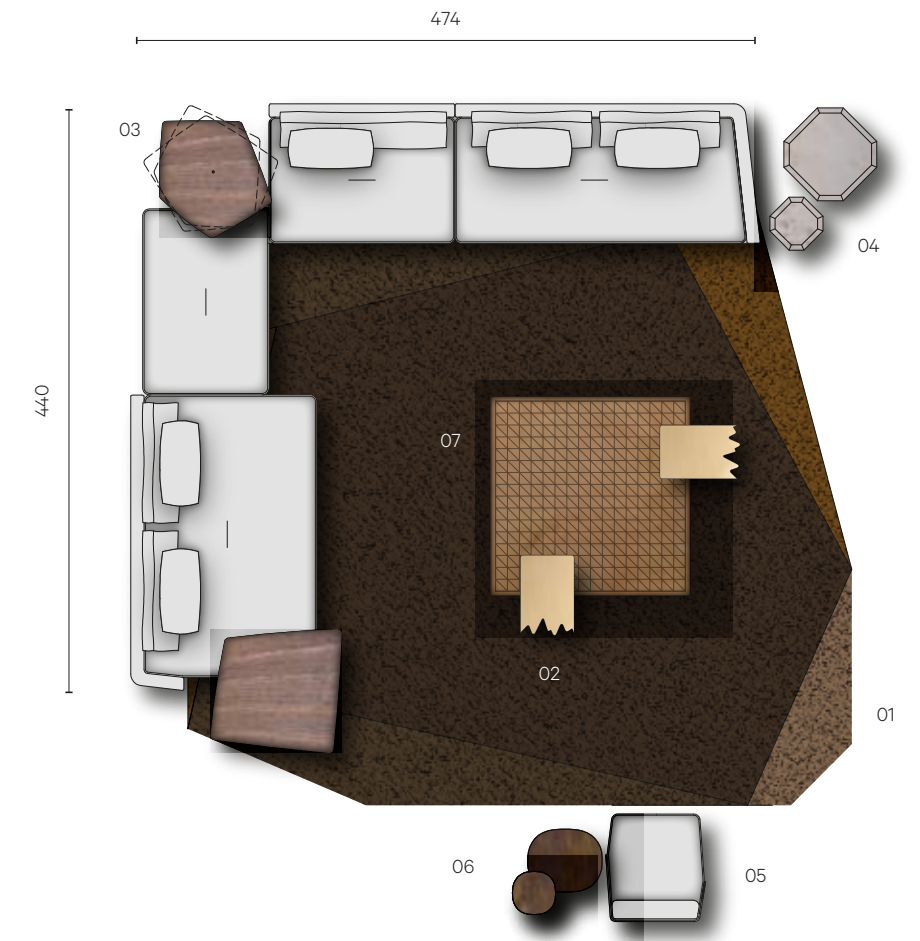

HUMAN SOFA

# Composition 02

- 01. H-Silk Carpet
- 02. Shift Table
- 03. Touch Coffee Table
- 04. W-Table
- 05. Human Armchair
- 07. Strip Lounge Armchair

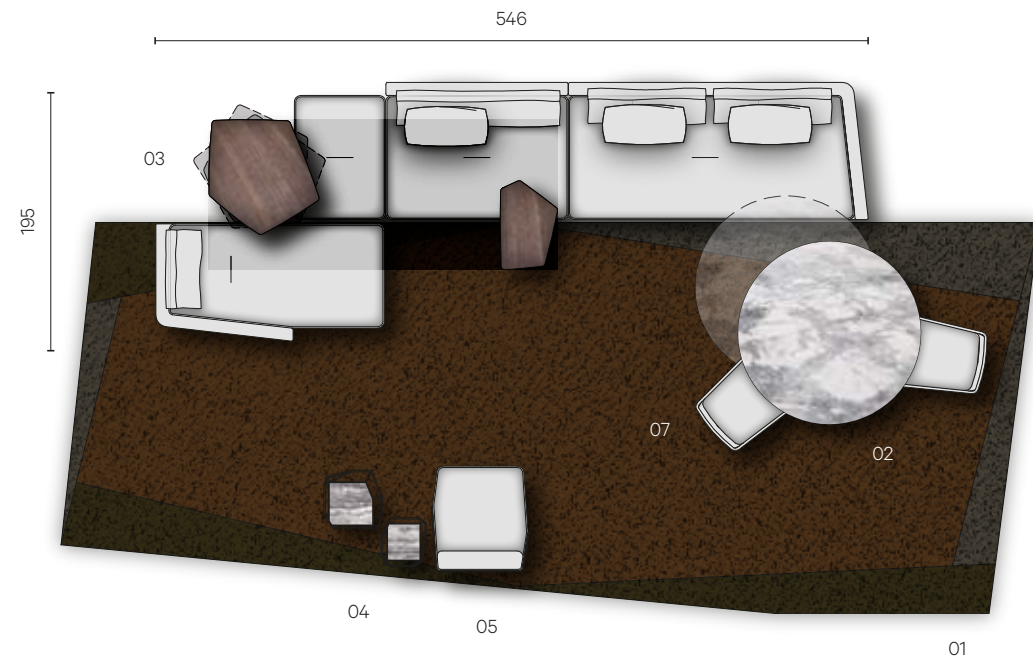

HUMAN SOFA

# Composition 04

- 01. H-Silk Carpet
- 02. Shift Table
- 03. Touch Coffee Table
- 04. W-Table
- 05. Echo Armchair
- 06. Strip Lounge Armchair

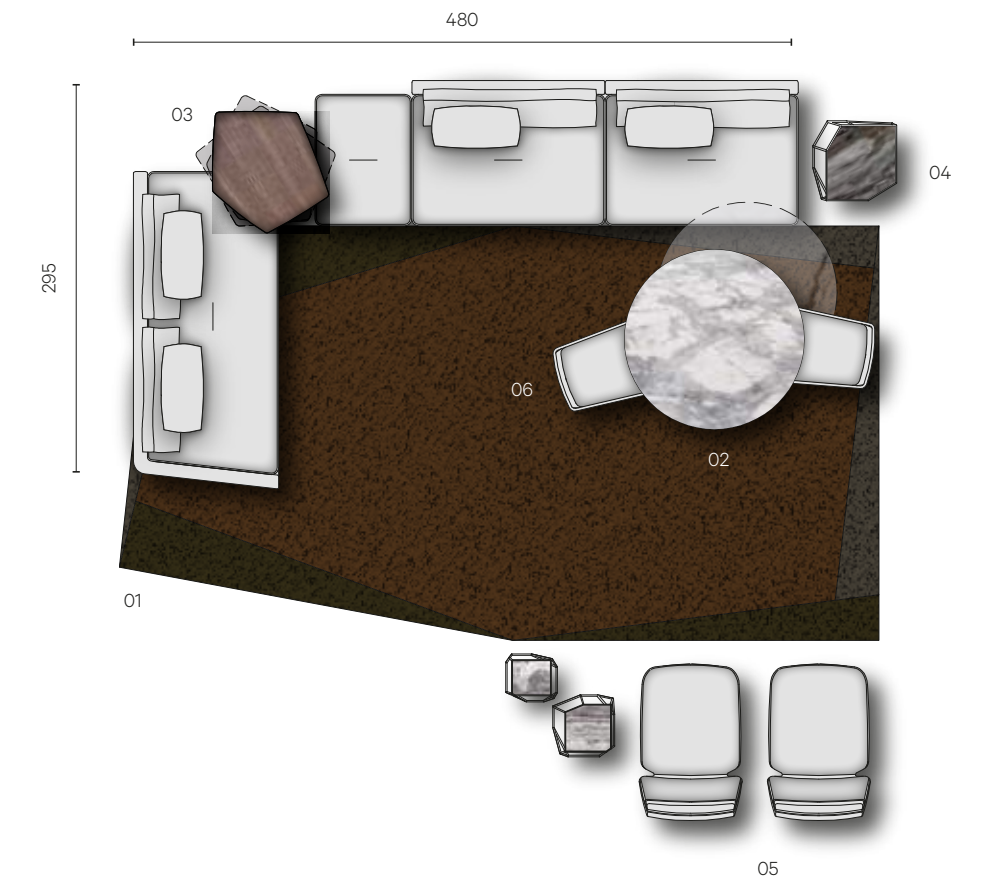

## WALL CLIPS 7/9/10/12

Design Massimo Castagna

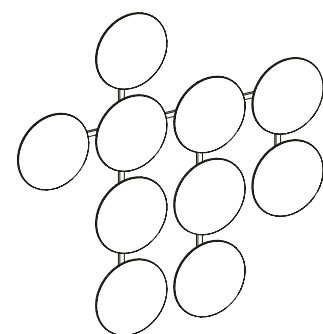

Wall sconce energy saving led lamp with warm light, (energy efficiency index A). Clips, Ø 23,5 cm

**Finish**  
Burnished Steel, Burnished Brass by hand using traditional techniques.

H-Silver®: pure 99,9% silver on Brass, burnished by hand using traditional techniques, which is a result of an exclusive HENGE recipe. Shine Copper

**Composition**

7 Clips; 7x4,3W 330Lm - 3000K  
9 Clips; 9x4,3W 330Lm - 3000K  
10 Clips; 10x4,3W 330Lm - 3000K  
12 Clips; 12x4,3W 330Lm - 3000K

Lampada a parete a led basso consumo (classe energetica tipo A) con luce calda. Diametro "bottoni" Ø 23,5 cm

**Finitura**

Acciaio brunito, Ottone brunito, a mano utilizzando tecniche tradizionali.

H-Silver®: argento (purissimo) 99,9% su ottone, brunito a mano utilizzando tecniche tradizionali, frutto di una ricetta esclusiva HENGE. Rame Lucido

**Composizione**

7 bottoni; 7x4,3W 330Lm - 3000K  
9 bottoni; 9x4,3W 330Lm - 3000K  
10 bottoni; 10x4,3W 330Lm - 3000K  
12 bottoni; 12x4,3W 330Lm - 3000K

## WALL CLIPS SINGLE

Design Massimo Castagna

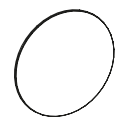

Wall sconce energy saving led lamp with warm light, (energy efficiency index A). Clip, Ø 40 cm

**Finish**  
Burnished Steel, Burnished Brass by hand using traditional techniques.

H-Silver®: pure 99,9% silver on Brass, burnished by hand using traditional techniques, which is a result of an exclusive HENGE recipe. Shine Copper

**Composition**

1 clip; 4,3W 330Lm - 3000K

Lampada a parete a led basso consumo (classe energetica tipo A) con luce calda. Diametro "bottone" Ø 40 cm

**Finitura**

Acciaio brunito, Ottone brunito, a mano utilizzando tecniche tradizionali.

H-Silver®: argento (purissimo) 99,9% su ottone, brunito a mano utilizzando tecniche tradizionali, frutto di una ricetta esclusiva HENGE. Rame Lucido

**Composizione**

1 bottone; 4,3W 330Lm - 3000K

## TELE LIGHT

Design Massimo Castagna

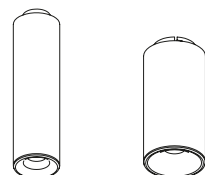

Ceiling led light.

Burnished Brass and H-Silver by hand using traditional techniques, Shine Brass and Shine Copper.

**DIMENSIONS**

Ø 9 cm x 33 cm - 5,3W 350Lm - 3000K  
Ø 12 cm x 25 cm - 5,3W 350Lm - 3000K

Lampada a soffitto,

Finitura ottone e H-silver brunito a mano secondo le tecniche tradizionali, ottone e rame lucido.

**DIMENSIONI**

Ø 9 cm x 33 cm - 5,3W 350Lm - 3000K  
Ø 12 cm x 25 cm - 5,3W 350Lm - 3000K

## TAPE LIGHT

Design Massimo Castagna

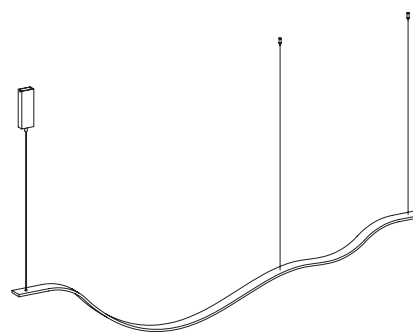

Pendant energy saving led (energy efficiency index A) lamp with warm light, of various sizes and types of illumination; incorporating transformers in the ceiling rosette, low voltage power supply to the rings through the suspension cables.

Standard overall height 180 cm

**DIMENSIONS**

SINGOLA 140 cm 18W 1380Lm 3000k  
SINGOLA 180 cm 24W 1874Lm 3000k  
SINGOLA 200 cm 27W 2139Lm 3000k  
PAIR 140 cm 36W 2760Lm 3000k  
PAIR 180 cm 48W 3749Lm 3000k  
PAIR 200 cm 55W 4278Lm 3000k

Lampada a sospensione a led (classe energetica tipo A) basso consumo con luce calda, in diverse misure e tipologie di emissione luminosa; trasformatori inseriti nel rosone, alimentazione degli anelli a bassa tensione realizzata tramite i cavi di sospensione.

Sviluppo standard 180 cm

**DIMENSIONI**

SINGOLA 140 cm 18W 1380Lm 3000k  
SINGOLA 180 cm 24W 1874Lm 3000k  
SINGOLA 200 cm 27W 2139Lm 3000k  
COPPIA 140 cm 36W 2760Lm 3000k  
COPPIA 180 cm 48W 3749Lm 3000k  
COPPIA 200 cm 55W 4278Lm 3000k

Tape Light . Single A

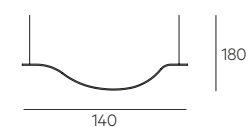

Tape Light . Single B

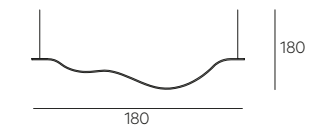

Tape Light . Single C

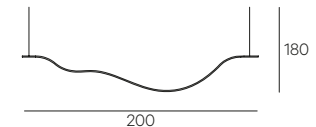

Tape Light . Pair A

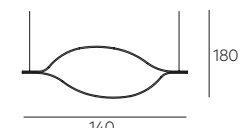

Tape Light . Pair B

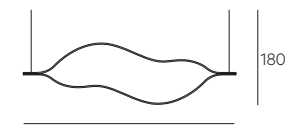

Tape Light . Pair C



## TAPE LIGHT WALL

Design Massimo Castagna



Energy saving led (energy efficiency index A) wall lamp with warm light, of various sizes and types of illumination; incorporating transformers in the rosette.

Standard overall height 180 cm

**DIMENSIONS**

SINGOLA 140 cm 18W 1380Lm 3000k  
SINGOLA 180 cm 24W 1874Lm 3000k  
SINGOLA 200 cm 27W 2139Lm 3000k

Lampada a muro a led (classe energetica tipo A)

basso consumo con luce calda, in diverse misure e tipologie di emissione luminosa; trasformatori inseriti nel rosone.

Sviluppo standard 180 cm

**DIMENSIONI**

SINGOLA 140 cm 18W 1380Lm 3000k  
SINGOLA 180 cm 24W 1874Lm 3000k  
SINGOLA 200 cm 27W 2139Lm 3000k

## LIGHT RING HORIZONTAL POLYGONAL

Design Massimo Castagna

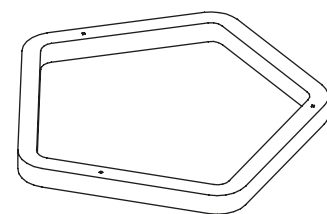

Pendant energy saving led (energy efficiency index A) lamp with warm light, formed with rings of various sizes and types of illumination; incorporating transformers in the ceiling rosette, low voltage power supply to the rings through suspension cables. Standard overall height 180 cm

Finish

Brass hand-burnished using traditional techniques.

H-Silver®: pure 99.9% silver on Brass, burnished by hand using traditional techniques, which is a result of an exclusive Henge recipe

DIMENSIONS

Ring Ø 180 cm with leds pointing downward 64W 5082Lm 3000K  
 Ring Ø 220 cm with leds pointing downward 89W 11880Lm 3000K  
 Ring Ø 280 cm with leds pointing downward 120W 16040Lm 3000K  
 Ring Ø 300 cm with leds pointing downward 132W 17600Lm 3000K

Lampada a sospensione a led (classe energetica tipo A)

basso consumo con luce calda, formata da anelli in diverse misure e tipologie di emissione luminosa; trasformatori inseriti nel rosone, alimentazione degli anelli a bassa tensione realizzata tramite i cavi di sospensione.

Sviluppo standard 180 cm

Finitura

Ottone brunito a mano secondo le tecniche tradizionali.

H-Silver®, argento (purissimo) 99.9% su ottone, brunito a mano utilizzando tecniche tradizionali, frutto di una ricetta esclusiva Henge.

DIMENSIONI

Anello Ø 180 con led rivolti verso il basso 64W 5082Lm 3000K  
 Anello Ø 220 con led rivolti verso il basso 89W 11880Lm 3000K  
 Anello Ø 280 con led rivolti verso il basso 120W 16040Lm 3000K  
 Anello Ø 300 con led rivolti verso il basso 132W 17600Lm 3000K

Light Ring Horizontal Polygonal Ø180

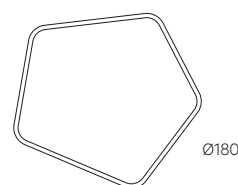

Ø180

Light Ring Horizontal Polygonal Ø220

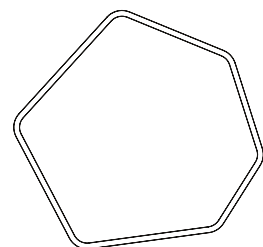

Ø220

Light Ring Horizontal Polygonal Ø280

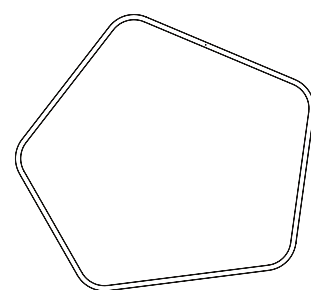

Ø280

Light Ring Horizontal Polygonal Ø300

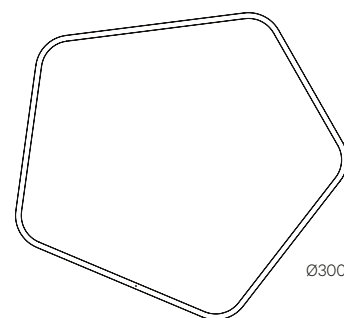

Ø300

## AIRLIGHT CHANDELIER

Design Massimo Castagna

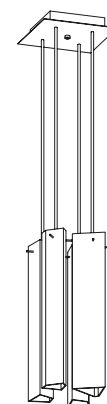

Dimmable pendant lamp in several compositions made up transparent and Grey Murano glass polyhedral canes. Structure in burnished brass and steel by hand using traditional techniques. Available in 3 typology A - B - C.

Glass polyhedral canes: 42,5 h and 85cm h

Halogen light 3000 k 35 W 860 Lm, dimmable.

Murano glass polyhedral cane - 1 composition 35 W 860 Lm 3000 K

Murano glass polyhedral canes - 3 composition 105 W 2580 Lm 3000 K

Murano glass polyhedral canes - 4 composition 140 W 3440 Lm 3000 K

Murano glass polyhedral canes - 6 composition 210 W 5160 Lm 3000 K

Lampada sospensione in varie composizioni formata da canne poliedriche in vetro trasparente e grigio di Murano soffiato a mano. Struttura in acciaio e ottone brunito a mano secondo le tecniche tradizionali.

3 tipologie di canne in vetro A - B - C

Altezza canne 42,5 e 85 cm

Luce alogena 3000 k 35 W 860 Lm, dimmerabile.

Composizione a 1 canna 35 W 860 Lm 3000 K

Composizione a 3 canne 105 W 2.580 Lm 3000 K

Composizione a 4 canne 140 W 3.440 Lm 3000 K

Composizione a 6 canna 210 W 5.160 Lm 3000 K

Airlight Chandelier . H 85  
 4 glass polyhedral canes  
 4 Canne poliedriche in vetro

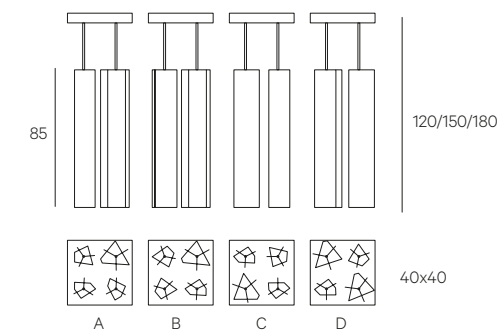

Airlight Chandelier . H 85  
 6 glass polyhedral canes  
 6 Canne poliedriche in vetro

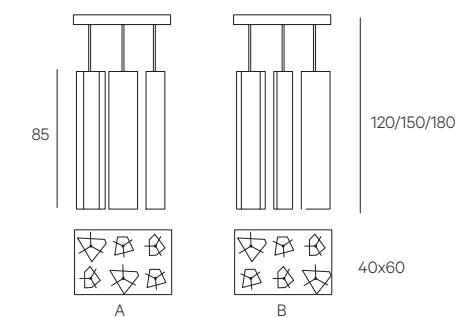

## LIGHT 5 RING MULTIMATERIC

Design Massimo Castagna

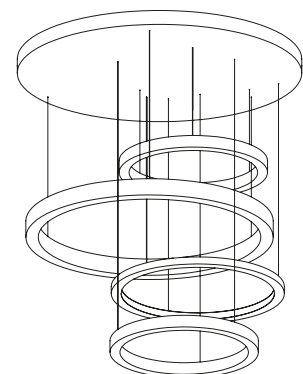

Dimmable pendant led lamp (energy efficiency index A), energy saving with warm light, in several compositions made up of burnished finish Brass rings or black burnished finish steel rings. H-Silver®. Handmade with traditional craftsmanship, available in different sizes and types of light emission; transformers inserted in the ceiling rosette, rings powered with low voltage through suspension wires.

5 ring composition (from top to bottom)

- 1 x Ø 60 cm ring with Burnished Black Brass 24W 1900Lm 3000k
  - 2 x Ø 100 cm rings with Termowood 41W 3268Lm 3000k
  - 3 x Ø 70 cm rings with Shine Brass 26W 2109Lm 3000k
  - 4 x Ø 60 cm rings with Burnished Black Brass 24W 1900 Lm 3000k
  - 5 x Ø 50 cm rings with Burnished Brass 22W 1691Lm 3000k
- Minimum overall height 120 cm.  
Total 137W 10868Lm

Lampada sospensione a led (classe energetica tipo A), dimmerabile, basso consumo con luce calda, in varie composizioni formata da anelli profilati in ottone finitura brunita, o acciaio brunito nero. H-Silver®. Secondo le tecniche tradizionali realizzata a mano in diverse misure e tipologie di emissione luminosa; trasformatori inseriti nel rosone, alimentazione degli anelli a bassa tensione realizzata tramite i cavi di sospensione.

Composizione a 5 anelli (dall'alto verso il basso)

- 1 anello da Ø 60 cm ottone brunito nero 24W 1900Lm 3000k
  - 2 anello da Ø 100 cm legno termo 41W 3268Lm 3000k
  - 3 anello da Ø 70 cm ottone lucido 26W 2109Lm 3000k
  - 4 anello da Ø 60 cm ottone brunito nero 24W 1900 Lm 3000k
  - 5 anello da Ø 50 cm ottone brunito 22W 1691Lm 3000k
- Sviluppo minimo 120 cm.  
Totale 137W 10868Lm

## H-SILK CARPET

Design Massimo Castagna

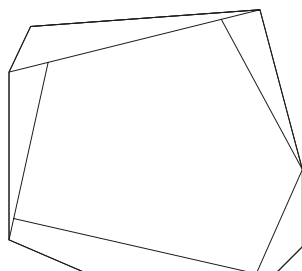

Structure  
Quality 100% silk.  
Color and weave of the yarns entirely handmade.  
DIMENSIONS  
270 cm x 400 cm  
300 cm x 750 cm  
450 cm x 500 cm  
Sizes can be customized per sq

Struttura  
Qualità 100% seta.  
Colorazione dei filati e tessitura interamente realizzate a mano.  
DIMENSIONI  
270 cm x 400 cm  
300 cm x 750 cm  
450 cm x 500 cm  
per misure customizzate prezzi al mq

Carpet . Tappeto 270x400

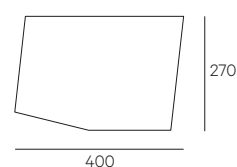

Carpet . Tappeto 300x750

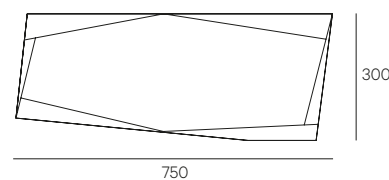

Carpet . Tappeto 450x500

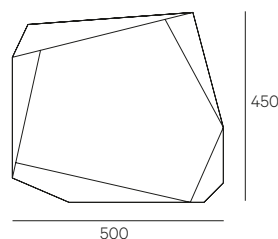

## BLACK MIRROR

Design Massimo Castagna

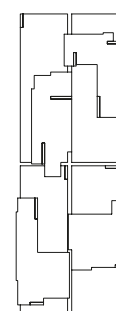

Structure  
1,8 cm and 2,5 cm thick solidwood.  
4 cm thick mirror antique by hand with insert in sand casted Bronze.  
DIMENSIONS  
69 cm x 216 cm  
75 cm x 197 cm  
70 cm x 197 cm  
72 cm x 197 cm

Struttura  
Legno listellare sp. 1,8 cm e 2,5 cm  
Specchio brunito nero sp. 0,4 cm con particolari in bronzo fuso con stampi a terra  
DIMENSIONI  
69 cm x 216 cm  
75 cm x 197 cm  
70 cm x 197 cm  
72 cm x 197 cm

Mirror Black A

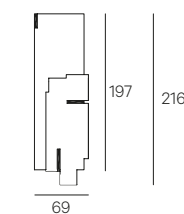

Mirror Black B

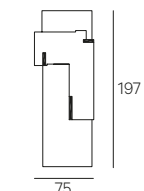

Mirror Black C

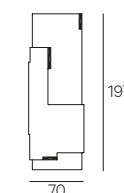

Mirror Black D

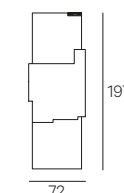

# Index

## Tables and chairs

EX-TRA CHAIR	pp. 23, 25, 29, 89, 91
K - TABLE CONSOLE	pp. 171
SAETTA TABLE	pp. 23, 27, 29, 89
SHIFT TABLE LOUNGE	pp. 39, 41

## Sofas and armchairs

HUMAN ARMCHAIR	pp. 131, 133
HUMAN SOFA	pp. 39, 43, 47, 49, 51
MYST - DAY BED	pp. 69
PULSE SOFA	pp. 57, 121, 129

## Coffee tables

BE-MINE COFFEE TABLE	pp. 65, 67, 127
D -CODE TABLE	pp. 121, 129, 131
GALAXY MAXI COFFEE TABLE	pp. 111
MUSHROOM TABLE	pp. 61, 123
TOUCH COFFEE TABLE	pp. 61, 123

## Cabinets

FRAME	pp. 141
PALAZZI	pp. 79, 81

## Bookshelves

BISTROT S	pp. 45
CAGE - B	pp. 109
LOOM FR	pp. 69, 71
LOOM SYSTEM	pp. 31, 135, 157, 167
STILE SET	pp. 59

## Lighting

AIRLIGHT CHANDELIER	pp. 93, 95
LIGHT 5 RING MULTIMATERIC	pp. 165, 167
LIGHT RING HORIZONTAL POLYGONAL	pp. 47
TAPE LIGHT	pp. 63, 107, 145, 147, 149
TELE LIGHT	pp. 115
WALL CLIPS	pp. 79, 81, 169

## Bar

OZONE	pp. 159
-------	---------

## Accessories

H-SILK CARPET	pp. 39, 43, 51, 57, 63, 69, 121, 129
---------------	--------------------------------------

CONCEPT, ART DIRECTION

Massimo Castagna - AD Architettura

PHOTO ART DIRECTION

Massimo Castagna - AD Architettura

PHOTO

Andrea Pancino

Mattia Pasin

Max Zambelli

ARTIST

Pierluigi Slis

STYLING

Elena Caponi Studio

GRAPHIC DESIGN

Gusto IDS

PRINTING

Grafiche Antiga

July 2017

THANKS TO

Adi Toch

Alexa Lixfeld

Ariane Prin

Charlotte Jankowski

Daandesign

Daphna Laurens

Davide Aquini

Edmond Byrne

Chidini1961

Ginger Brown

Jeremie Duprey

Jule Waibel

Juliette Bigley

Kat Evans

Katharina Eisenkoeck

Marlene Huissod

Mathias Kuenzler

Matthias Kaiser

Patricia Shone

Sarah Linda Forrer

Sophie Dries

Thomas Eyck

Verreum



HENGE

Via della Spiga 7

20121 Milano (MI) - Italy

Tel. +39.0438 1710600 - Fax +39.0438 1710113

www.henge07.com . atelier@henge07.com

Open by appointment



Offices and Factory

Via G. Verdi, 45

31010 Farra di Soligo (TV) - Italy



[www.henge07.com](http://www.henge07.com)