

# 201∞ COLLECTION

A TALE OF AN INFINITE PRESENT

Minotti

**Minotti**

# 201∞ COLLECTION

coordinated by Rodolfo Dordoni

Il 2018 è un anno per noi davvero speciale, una tappa fondamentale nel nostro percorso evolutivo. Giunti all'anniversario dei settant'anni dell'azienda, un traguardo che attesta il forte impegno nell'interior design, ci presentiamo con una collezione poliedrica, nata da un progetto aperto ai contributi di filosofie progettuali radicate in background culturali ben distinti. Una collezione che mantiene intatti quei valori a noi cari, di eleganza delle forme, sobrietà del design e continuità nella tradizione insiti nel nostro DNA, ma aperta alle sollecitazioni in arrivo da punti cardinali diversi. Interamente coordinata da Rodolfo Dordoni, nel segno della continuità, accoglie oggi la cifra stilistica di quattro designer di matrice internazionale. Dall'Italia, lo stesso Dordoni, che da vent'anni partecipa al successo della nostra avventura, riafferma il suo stile inconfondibile, legato ai principi sia del razionalismo che dell'interior decoration, disegnando arredi timeless, perfetta espressione dell'identità Minotti, e con rimandi al mondo dell'arte contemporanea. Dal Giappone, Nendo ci porta il suo segno grafico, leggero, quella poesia sottile che percorre il suo design, quell'attenzione ai volumi, agli spessori e ai dettagli inaspettati che invita a scoprire da vicino le sue creature. Dalla Francia, Christophe Delcourt ci restituisce l'appeal della cultura francese per la decorazione, i materiali preziosi, le superfici lavorate con savoir-faire artigianale, l'alta ebanisteria che sposa tecnologie high-end. Dal Brasile, Marcio Kogan ci trasmette il suo approccio architettonico al progetto per l'outdoor, mutuando elementi e materiali dal mondo della natura e della nautica, abolendo la frattura tra interno e esterno. La 2018 Collection si fa interprete di tutti questi stimoli e dichiara il suo sguardo al futuro, inserendo nel nome il simbolo dell'infinito. Un presente infinito che segna l'evoluzione della nostra strategia progettuale, trasversale nello stile e nei linguaggi. Con una punta di orgoglio guardiamo al lavoro svolto in questo ultimo anno e ci auguriamo di poter trasferire alla community Minotti nel mondo tutta l'energia e la passione che lo hanno alimentato.

—

**Renato e Roberto Minotti**

*2018 is a very special year for us, a breakthrough in our evolutionary path. Having reached the seventieth anniversary of the company, a milestone that attests our strong commitment to interior design, we present a multifaceted collection, born from a project open to contributors with design philosophies rooted in various cultural backgrounds. A collection that keeps intact the values so dear to us, of elegance of forms, of sobriety in design and of continuity in the tradition inherent to our DNA, but open to the solicitations coming from different cultures. Entirely coordinated by Rodolfo Dordoni, as a sign of continuity, today it welcomes the stylistic input of four international designers. From Italy, Dordoni himself, who has been part of the success of our adventure for now twenty years, reaffirms his unmistakable style. Linked to the principles of both rationalism and interior decoration, his timeless pieces, which are the perfect expression of Minotti identity, carry references to the world of contemporary art. From Japan, Nendo brings us his light graphic tone. With the subtle poetry that runs through his designs, the attention to volumes, thicknesses and unexpected details that invite us to discover his creations closely. From France, Christophe Delcourt reconnects us with the affection of French culture for decoration, precious materials, surfaces worked with artisanal savoir-faire and fine cabinetmaking, combined with high-end technologies. From Brazil, Marcio Kogan conveys us his architectural approach to outdoor designs, borrowing elements and materials from the worlds of nature and yachting, abolishing the boundaries between inside and outside. The 2018 Collection interprets all these stimuli and declares its gaze on the future, inserting the symbol of the infinite into its name. An infinite present that marks the evolution of our design strategy, transversal in style and languages. With a touch of pride, we look at the work done in this past year and hope to transfer all the energy and passion that have fueled it to the entire Minotti community around the world.*

*2018 ist für uns ein ganz besonderes Jahr, eine entscheidende Etappe auf dem Weg unserer Entwicklung. Die Firma feiert ihr siebzigjähriges Bestehen, ein Ziel, das mit intensivem Engagement im Interior Design erreicht wurde, und präsentiert sich mit einer polyedrischen Kollektion, ein Projekt, das sich dem Beitrag von kreativen Ideen öffnete, die in sehr unterschiedlichen Kulturen verwurzelt sind. Eine Kollektion, die die Werte achtet, die uns am Herzen liegen, Eleganz der Formen, schlichtes Design und Kontinuität der uns eigenen Tradition, die aber Anregungen aus verschiedenen Himmelsrichtungen offensteht. Unter der Regie von Rodolfo Dordoni, im Zeichen der Kontinuität, gesellt sich heute die stilistische Griffe von vier Designern internationaler Prägung hinzu. Für Italien bestätigt Dordoni selbst - der seit zwanzig Jahren am Erfolg unseres abenteuerlichen Werdegangs beteiligt ist - seinen unverkennbaren Stil, gebunden an die Prinzipien des Rationalismus, aber auch der Interior Decoration, und schafft zeitlose Einrichtung, perfekter Ausdruck der Identität des Labels Minotti, auch mit einem Auge auf die Welt der zeitgenössischen Kunst. Aus Japan bringt uns Nendo seinen graphisch geprägten, leichten Stil, die schwerelose Poesie, die sich durch sein Design zieht, die Aufmerksamkeit für Volumen, Materialstärken und überraschende Details, eine Einladung, seine Schöpfungen aus der Nähe zu betrachten. Christophe Delcourt aus Frankreich erinnert uns an den Charme, den die Dekoration aus der französischen Kultur schöpft, kostbare Materialien, mit handwerklicher Fertigkeit bearbeitete Flächen, hohe Tischlerkunst vereint mit High-End-Technologie. Aus Brasilien vermittelt uns Marcio Kogan seine architekturähnliche Idee für das Outdoor-Projekt, für das er Elemente und Materialien aus der Natur und der Nautik entlehnt, um Innen- und Außenbereich mit einander zu verbinden. Die 2018 Kollektion ist Ausdruck aller dieser Anregungen und zeigt ihren Blick auf die Zukunft, indem sie das Zeichen für Unendlichkeit in ihren Namen aufnimmt. Eine unendliche Gegenwart, die die Evolution unserer Projektstrategie zeichnet, transversal in Stil und Ausdruck. Wir schauen mit etwas Stolz auf unsere Arbeit im letzten Jahr und hoffen, die ganze Energie und Leidenschaft, die wir einsetzten, der gesamten Minotti-Community in der Welt übermitteln zu können.*

*2018 est une année très spéciale pour nous, un moment charnière de notre développement. Célébrant le soixante-dixième anniversaire de l'entreprise, une étape qui témoigne d'un engagement durable pour le design d'intérieur, nous présentons une collection aux multiples facettes, née d'un projet ouvert aux contributions de philosophies conceptuelles enracinées dans des contextes bien distincts. Une collection qui conserve les valeurs qui nous sont chères, l'élégance des formes, la sobriété du design et la foi dans la tradition inhérente à notre ADN, mais perméable aux sollicitations provenant de différentes cultures. Entièrement coordonnée par Rodolfo Dordoni, dans un souci de continuité, elle accueille aujourd'hui l'identité stylistique de quatre designers internationaux. D'Italie, le même Dordoni, qui participe depuis vingt ans au succès de notre aventure, réaffirme son style caractéristique, défini par les principes du rationalisme et de la décoration intérieure, en concevant des meubles intemporels aux références au monde de l'art contemporain. L'expression parfaite de l'identité de Minotti. Du Japon, Nendo nous apporte son langage graphique et lumineux, la subtile poésie qui traverse son design, cette attention aux volumes, aux épaisseurs et aux détails inattendus qui nous invite à découvrir ses créations de plus près. De France, Christophe Delcourt partage avec nous l'attrait de la culture française pour la décoration, ainsi que pour les matériaux précieux, les surfaces travaillées avec un savoir-faire artisanal, et l'ébénisterie alliée aux technologies haut de gamme. Du Brésil, Marcio Kogan transmet sa vision architecturale au projet pour l'extérieur, en empruntant des éléments et des matériaux du monde de la nature et de la navigation de plaisance, et en supprimant la frontière entre intérieur et extérieur. La 2018 Collection réinterprète tous ces stimuli et contemple le futur en introduisant le symbole de l'infini dans son nom. Un présent sans fin qui marque l'évolution de notre stratégie, transversale dans le style et les langues. Avec une pointe de fierté, nous regardons le travail accompli cette année et nous espérons transmettre toute l'énergie et la passion qui l'ont alimenté à l'ensemble de la communauté Minotti dans le monde.*

# INDOOR



**ALEXANDER** Rodolfo Dordoni design 08



**GRANVILLE** Christophe Delcourt design 50



**DAMIER** Rodolfo Dordoni design 34



**RUSSELL** Rodolfo Dordoni design 36



**TAPE** nendo design 68



**ALBERT&ILE** Gigi Radice design / Minotti Historic Archive 82



**MILTON** Rodolfo Dordoni design 104



**PRINCE "CORD" INDOOR** Rodolfo Dordoni design 78



**BENDER** Rodolfo Dordoni design 98



**WAVES** nendo design 90



**RING** nendo design 96



**SHIELDS** Minotti Studio design 108



**RAYS** Rodolfo Dordoni design 102



**BODEN** Gordon Guillaumier design 110



**OLIVER** Rodolfo Dordoni design 112



**LANCE** Rodolfo Dordoni design 126



**DAN** Christophe Delcourt design 116



**LOU** Christophe Delcourt design 128



**CARSON BOOKCASE** Rodolfo Dordoni design 142



**CURTIS** Rodolfo Dordoni design 144



**BLANCHE** Minotti Studio design 146



**DIBBETS IPANEMA** Rodolfo Dordoni design 24



**WISP** Minotti Studio design 12

# OUTDOOR



**QUADRADO** Marcio Kogan / studio mk27 design 152



**PRINCE "CORD" OUTDOOR** Rodolfo Dordoni design 164



**YORK "CORD" OUTDOOR** Rodolfo Dordoni design 172



**VAN DYCK "OUTDOOR"** Rodolfo Dordoni design 170



**DUCHAMP "OUTDOOR"** Rodolfo Dordoni design 166



**LEGER "OUTDOOR"** Rodolfo Dordoni design 168

## ALEXANDER

Rodolfo Dordoni design

Alexander seating system  
 Prince "Cord" Indoor armchair / Waves coffee table  
 Milton coffee table / Rays coffee table / Ring coffee table  
 Bender console table / Wisp rug







Alexander seating system  
Damier "Island" ottoman / Milton coffee table / Wisp rug







Alexander seating system  
Tape armchairs without armrests / Milton coffee table  
Shields coffee table / Ring coffee table  
Blanche lamp / Wisp rug





Alexander seating system  
Prince "Cord" Indoor armchair and footstool  
Damier "Island" ottoman / Milton coffee table  
Shields coffee table / Waves coffee table / Boden coffee table  
Teddy cushion / Blanche lamps / Wisp rug





Alexander seating system  
Tape sofa and armchair / Damier "Island" ottoman  
Milton coffee table / Ring coffee tables / Boden coffee table  
Lou living "high" sideboard / Dibbets "Ipanema" rug



Alexander seating system  
Tape armchairs / Damier "Island" ottoman  
Oliver coffee table / Ring coffee table / Dan table  
Lance little armchairs / Wisp rug





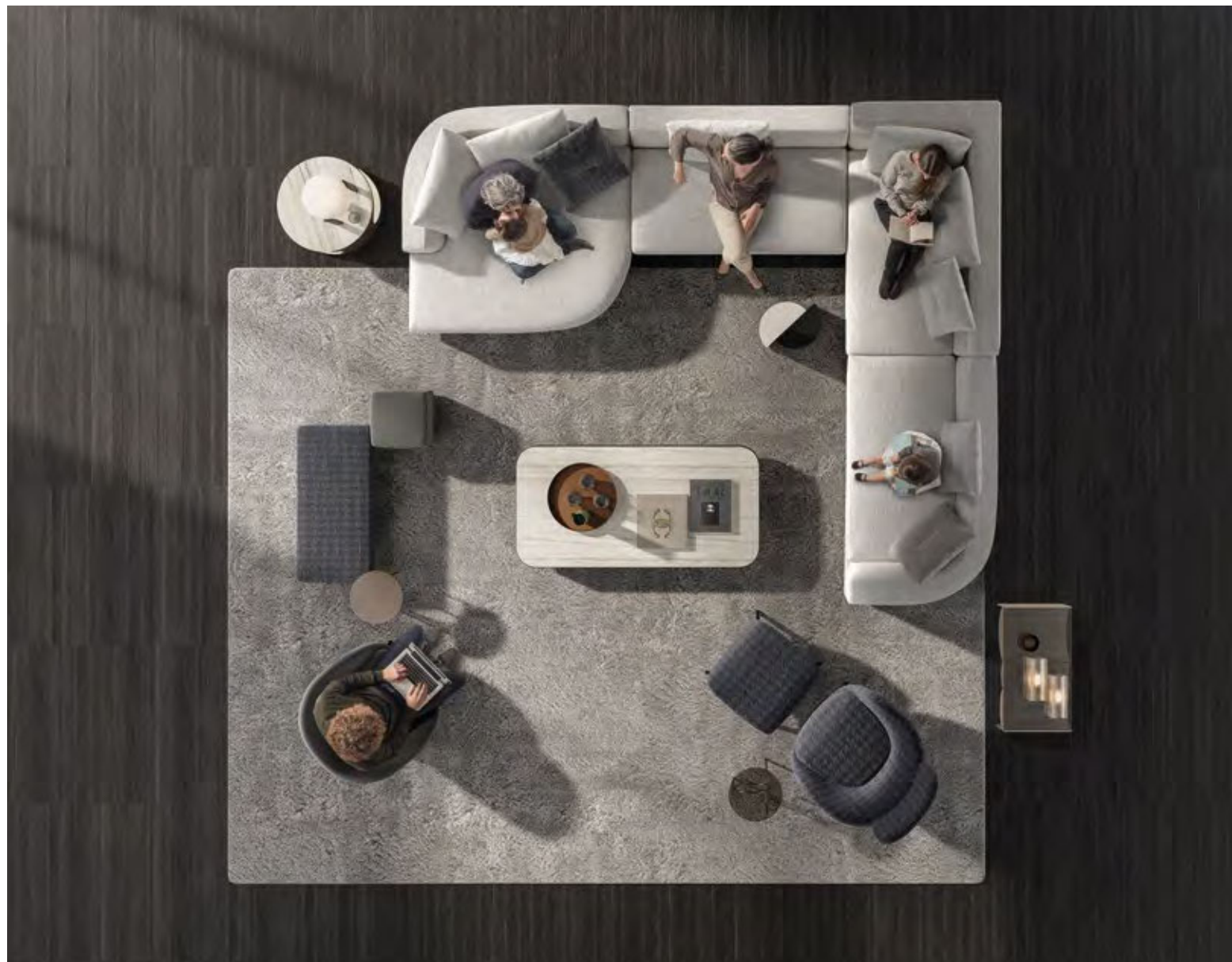

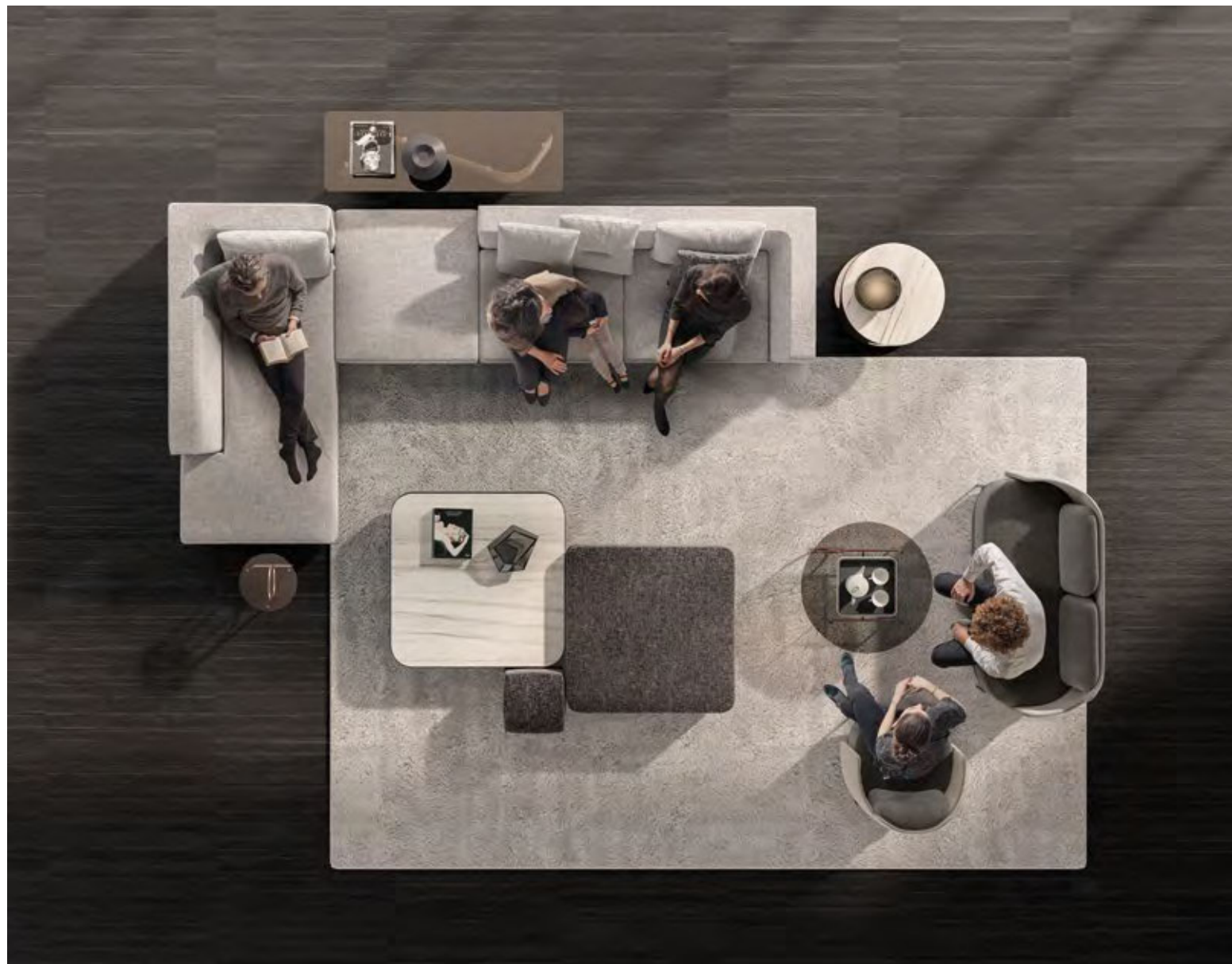

# DAMIER

Rodolfo Dordoni design

Damier "Island" ottomans  
Waves coffee table / Ring coffee tables / Milton coffee table  
Blanche lamps / Wisp rug



## RUSSELL

Rodolfo Dordoni design

Russell lounge little armchairs, angled sofa and armchair  
Teddy cushion / Shields coffee table / Oliver coffee table  
Lou console table / Wisp rug







Russell lounge little armchairs and angled sofa  
Bodem coffee tables / Lou bar sideboard / Dibbets "Rim" rug



[Russell](#) lounge little armchairs  
[Shields](#) coffee table / [Wisp](#) rug



[Russell](#) lounge little armchairs / [Oliver](#) coffee table / [Wisp](#) rug



[Russell](#) bergère and footstool / [Boden](#) coffee table / [Wisp](#) rug



[Russell](#) armchair / [Wisp](#) rug



[Russell](#) armchair / [Boden](#) coffee table / [Blanche](#) lamps / [Wisp](#) rug





Russell armchair / Wisp rug



[Russell](#) dining little armchairs / [Dan](#) table



[Russell](#) dining little armchair / [Dan](#) table / [Wisp](#) rug

## GRANVILLE

Christophe Delcourt design

Granville seating system  
Teddy cushion / Tape armchair / Damier ottoman  
Rays coffee table / Bender console table and coffee table  
Milton coffee table / Blanche lamps / Wisp rug





Granville seating system  
Teddy cushion / Tape armchairs without armrests  
Prince "Cord" Indoor armchair and footstool  
Bender coffee table and sidetable  
Waves coffee tables / Wisp rug

Granville seating system  
Tape sofa, armchairs with and without armrests  
Ring coffee tables / Waves coffee tables / Wisp rug





Granville seating system  
Tape armchairs / Ring coffee table / Milton coffee table  
Rays coffee table / Lou console table / Wisp rug





[Granville](#) seating system  
[Ring](#) coffee table / [Shields](#) coffee table  
[Prince "Cord"](#) Indoor armchair and footstool / [Wisp](#) rug



Granville seating system  
Ring coffee table / Oliver coffee table / Rays coffee table  
Tape armchair without armrests / Lou living "low" sideboards  
Wisp rug



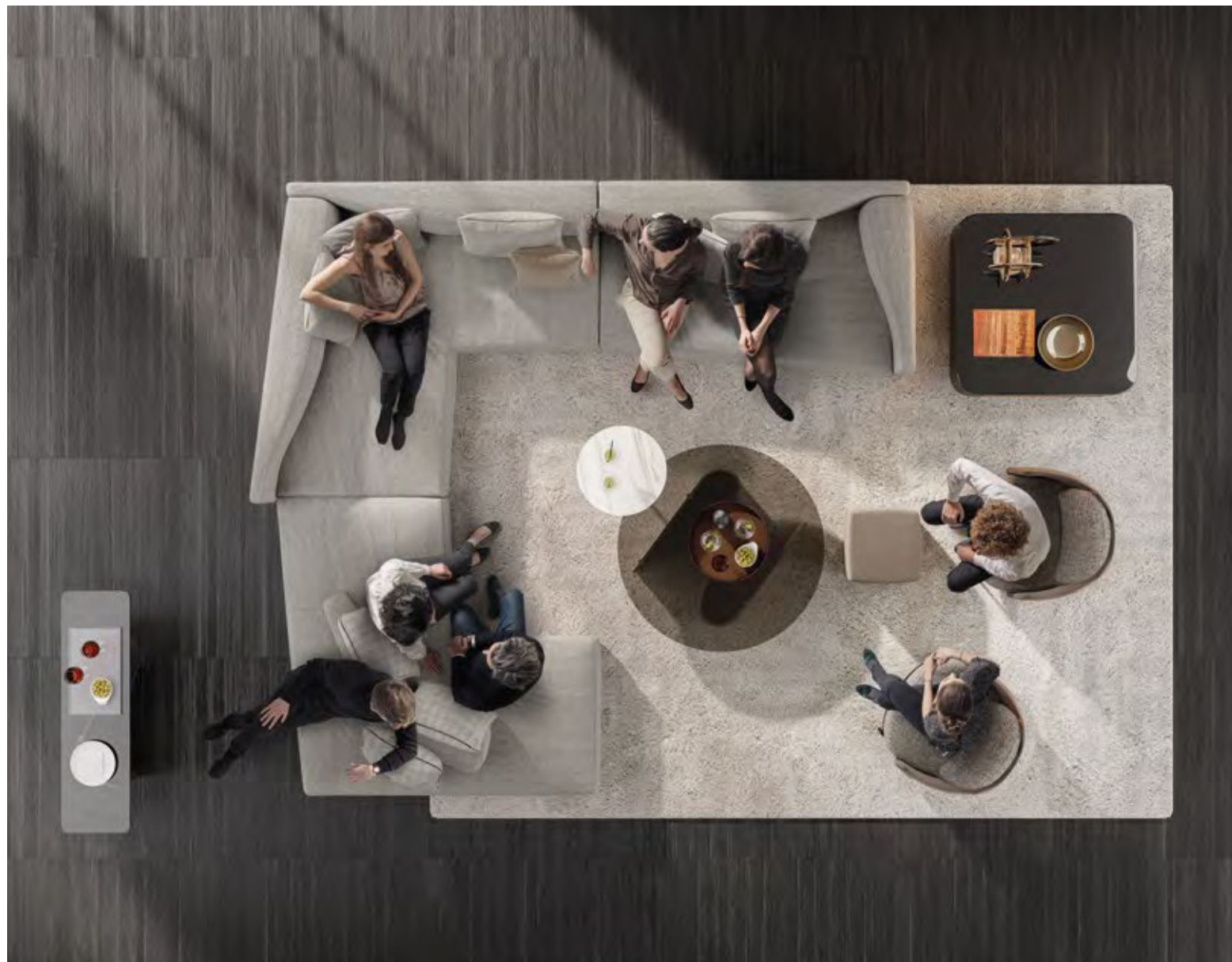

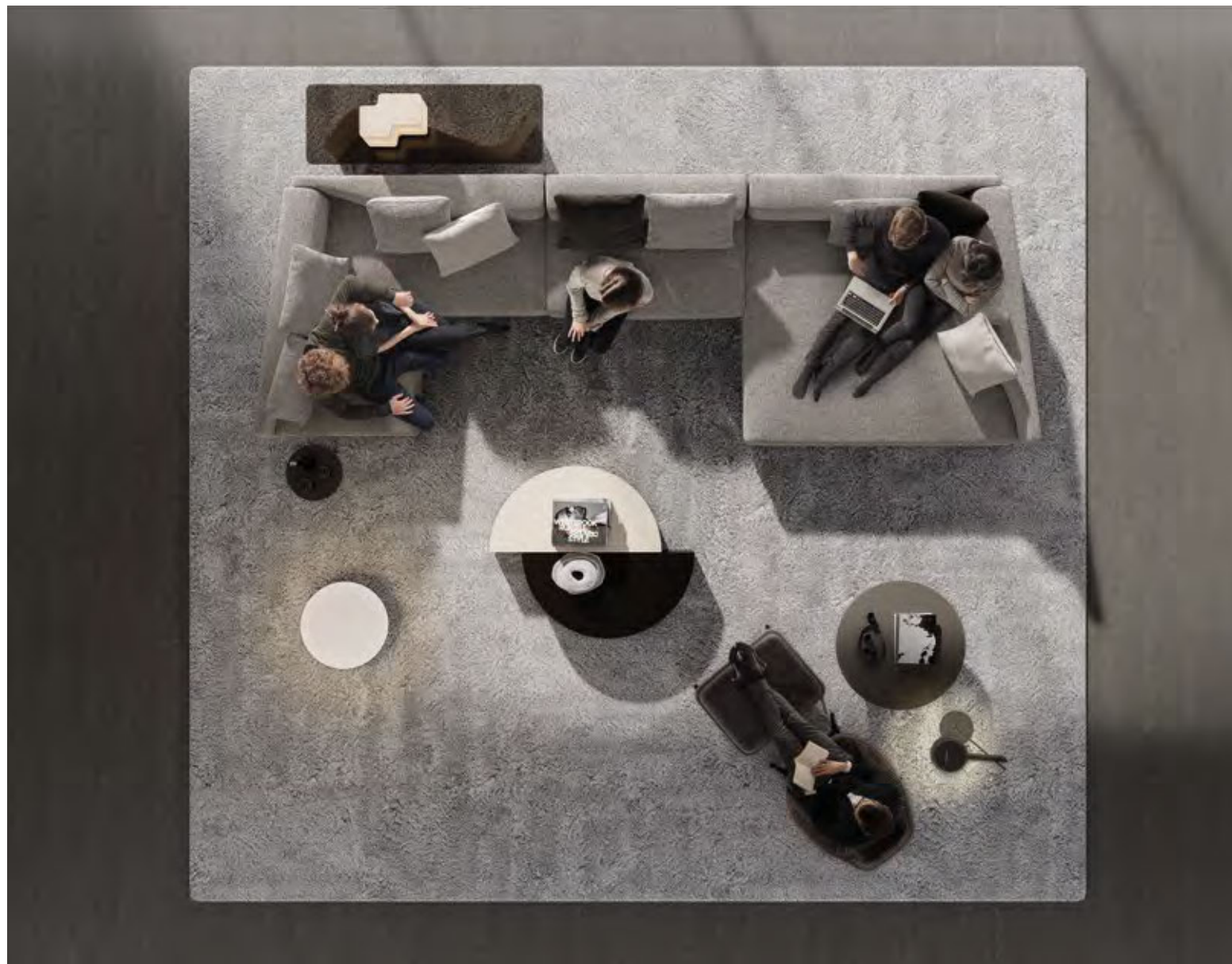

## T A P E

nendo design

Tape sofa and armchairs without armrests  
Oliver lounge table / Ring coffee table / Wisp rug





Tape sofa, armchairs with and without armrests, footstool  
Ring coffee tables / Waves coffee table / Wisp rug



[Tape](#) armchairs with and without armrests / [Ring](#) coffee table / [Wisp](#) rug



Tape armchairs without armrests / Ring coffee table / Wisp rug / Blanche lamp



Tape bergère, armchair and footstool  
Waves coffee table / Ring coffee table / Wisp rug



[Tape](#) armchairs without armrests / [Ring](#) coffee table / [Milton](#) coffee table / [Dibbets Ipanema](#) rug



PRINCE  
CORD  
INDOOR

Rodolfo Dordoni design

Prince "Cord" Indoor armchair and footstool  
Ring coffee table / Damier ottoman / Wisp rug





Prince "Cord" Indoor armchair and footstool  
Boden coffee table / Granville seating system / Wisp rug

**ALBERT & ILE**

Gigi Radice design / Minotti Historic Archive

Albert angled sofa and armchairs  
Milton coffee table / Rays coffee table / Lou bar sideboard  
Wisp rug







[Ile](#) armchair and lounge sofa  
[Rays](#) coffee table / [Curtis](#) bed / [Damier](#) ottoman  
[Ring](#) coffee table / [Milton](#) nightstand / [Wisp](#) rug



# WAVES

nendo design

Waves coffee tables





[Waves](#) coffee table / [Tape](#) sofa / [Wisp](#) rug



[Waves](#) coffee table / [Alexander](#) seating system / [Prince "Cord"](#) Indoor armchair / [Wisp](#) rug





# RING

nendo design

[Ring coffee table](#) / [Tape sofa](#) / [Wisp rug](#)



[Ring coffee table](#) / [Tape armchair](#) / [Dibbets Ipanema rug](#)

**BENDER**  
Rodolfo Dordoni design



Bender coffee table / Alexander seating system / Wisp rug



Bender side table / Granville seating system / Waves coffee table



## RAY S

Rodolfo Dordoni design



Rays coffee table / Milton coffee table  
Alexander seating system / Damier ottoman  
Ring coffee table / Wisp rug



Rays coffee table / Prince "Cord" Indoor armchair / Wisp rug

MILTON  
Rodolfo Dordoni design



[Milton](#) coffee table / [Granville](#) seating system / [Wisp](#) rug



[Milton](#) coffee table / [Alexander](#) seating system / [Shields](#) coffee table / [Wisp](#) rug



[Milton](#) coffee table / [Alexander](#) seating system / [Wisp](#) rug



**SHIELDS**  
Minotti Studio design

[Shields](#) coffee table / [Alexander](#) seating system / [Wisp](#) rug



[Shields](#) coffee table / [Granville](#) seating system / [Wisp](#) rug



**BODEN**  
Gordon Guillaumier design



[Boden](#) coffee table / [Granville](#) seating system / [Wisp](#) rug



[Boden](#) coffee table / [Alexander](#) seating system

**OLIVER**  
Rodolfo Dordoni design

Oliver lounge table  
Tape sofa and armchair without armrests / Wisp rug



Oliver coffee table / Russell lounge little armchairs / Wisp rug



Oliver coffee table  
Tape armchair / Alexander seating system / Wisp rug

**DAN**

Christophe Delcourt design

Dan table / Lance little armchairs  
Lou living "high" sideboard / Dibbets "Ipanema" rug











[Dan](#) table / [Russell](#) dining little armchairs / [Wisp](#) rug





LANCE  
Rodolfo Dordoni design



[Lance chair and little armchair](#) / [Dan table](#) / [Wisp rug](#)



**LOU**  
Christophe Delcourt design



[Lou](#) console table / [Russell](#) sofa / [Wisp](#) rug



Lou dining sideboard / Wisp rug









[Lou living "high" sideboard](#) / [Dibbets Ipanema rug](#)





Lou bar sideboard / Tape armchairs without armrests / Milton coffee tables / Wisp rug





[Lou](#) living/tv console table  
[Alexander](#) seating system / [Damier](#) ottoman  
[Blanche](#) lamps / [Wisp](#) rug



# CARSON

Rodolfo Dordoni design



Carson bookcase  
Alexander seating system / Damier "Island" ottoman  
Dibbets "Ipanema" rug



Carson bookcase / Lance little armchair / Dan table / Wisp rug

## CURTIS

Rodolfo Dordoni design

Curtis bed  
Ile armchair / Damier "Island" ottoman / Ring coffee table  
Oliver coffee table / Milton nightstands / Blanche lamps  
Wisp rug



BLANCHE  
Minotti Studio design



Blanche lamp / Calder "Bronze" console table



Blanche lamps  
Fil Noir armchairs / Noor coffee table / Dibbets "Diagonal" rug



[Blanche lamps](#) / [Alexander seating system](#) / [Bender side table](#) / [Wisp rug](#)



[Blanche lamp](#) / [Granville seating system](#) / [Wisp rug](#)

# 201∞ OUTDOOR

coordinated by Rodolfo Dordoni

La collezione 2018 dedicata all'outdoor nasce dalla volontà di conferire carattere agli spazi open-air, con elementi di grande comfort e flessibilità d'utilizzo, nel segno di una continuità tra in e out.

Gli arredi migrano con naturalezza dagli interni agli esterni, mantenendo il loro carattere d'innata eleganza e di elevato comfort, andando a comporre un living che entra in relazione con il contesto architettonico e naturale in cui si inserisce. Annullata la frattura tra dentro e fuori, cancellato il confine tra interno ed esterno, si delinea un landscape ininterrotto che permette di godere appieno del vivere en plein air.

In questa direzione è esemplare l'apporto progettuale di Marcio Kogan, architetto brasiliano famoso per le sue architetture aperte sulla natura circostante, con vetrate a tutta parete che annullano la cesura con l'esterno. Con un linguaggio progettuale ispirato al verde della sua terra, ai colori chiari e alle linee pulite delle sue opere architettoniche, il progettista, autodefinitosi "the square man",

ha messo a punto il sistema di sedute Quadrado, al tempo stesso consistente nei volumi e nei materiali e all'insegna della leggerezza nel disegno quasi flottante delle basi.

Va così a disegnare composizioni organiche, articolate e solari, partendo da un prodotto di matrice architettonica pensato per dialogare con lo spazio.

La collezione Outdoor 2018, interamente coordinata da Rodolfo Dordoni, mette in relazione i prodotti firmati dal designer milanese – una serie corposa di poltrone, sedute, tavoli e tavolini – con il sistema progettato da Kogan.

Andando a comporre un insieme armonico di elementi d'arredo pensati per gli spazi all'aperto e accomunati dalla leggerezza visiva e dal segno grafico delle forme.

*The 2018 Outdoor collection originates from the desire to give an identity to open-air spaces, with elements of great comfort and flexibility and with continuity between in and out. The furnishings seamlessly migrate from the interiors to the exteriors, maintaining their innate elegance and high comfort, composing a living space that dialogues with the surrounding architectural and natural context. The boundaries and the fractures between indoors and outdoors have been cancelled enabling an uninterrupted landscape to take shape and allowing the full enjoyment of living en plein air.*

*Exemplary is the contribution of Marcio Kogan, the Brazilian architect famous for his architectures open to the surrounding nature, with full-length windows that abolish the neat border with the outside. With a design language inspired by the lush green, the clear colours and the clean lines of the architectures of his home landscapes, the designer, self-defined "the square man", has developed the Quadrado seating system. The family of furnishings is characterized by substantial volumes and materials and, at the same time, by the lightness of the almost-floating bases. For a product of architectural matrix designed to dialogue with the space and that gives birth to organic, structured and bright compositions.*

*Entirely coordinated by Rodolfo Dordoni, the 2018 Outdoor collection brings together the products designed by the Milanese designer - a full-bodied series of armchairs, chairs, dining and occasional tables - with the seating system signed by Kogan. Composing a harmonious set of furnishing elements designed for outdoor spaces and combined with the visual lightness and the graphic sign of the forms.*

*Die Outdoor Kollektion 2018 drückt den Wunsch aus, den Zonen unter freiem Himmel mehr Charakter zu verleihen, mit sehr komfortablen Elementen, die extrem flexibel eingesetzt werden können, um eine perfekte Kontinuität zwischen In- und Outdoor herzustellen. Die Einrichtung wandert ganz natürlich vom Innen- in den Außenraum und verliert dabei nichts von ihrer angeborenen Eleganz und ihrem hohen Komfort, so dass ein Living entsteht, der sich dem Architektur- und Natur-Kontext anpasst, in den er sich einreihet. Die Diskrepanz zwischen drinnen und draußen verschwindet, die Trennwand zwischen Innen- und Außenbereich wird beseitigt, es entsteht eine ununterbrochene Wohnlandschaft, in der man das Leben an freier Luft voll genießen kann.*

*In dieser Hinsicht ist der Beitrag zum Projekt von Marcio Kogan beispielhaft. Der brasilianische Architekt ist berühmt für seine Architektur, die sich mit großen, raumhohen Fenstern zur umliegenden Natur hin öffnet, so dass die Trennung vom Außenraum entfällt. Das Konzept seines Projekts inspiriert sich an der üppigen Natur seines Landes, an den hellen Farben und den reinen Linien seiner Architektur. Der Architekt, der sich selbst als "the square man" bezeichnet, hat das Sitzprogramm Quadrado entworfen, das zwar, von den Volumen und Materialien her, recht massiv zu sein scheint, gleichzeitig aber mit dem fast schwebenden Design der Untergestelle im Zeichen der Leichtigkeit steht. Er entwirft also organische Kompositionen, untergliedert und sonnendurchflutet, ausgehend von einem Produkt architektonischer Prägung, das einen Dialog mit dem Raum anbahnt.*

*Die Outdoor Kollektion 2018, unter der Leitung von Rodolfo Dordoni, schafft eine enge Beziehung zwischen den vom Designer aus Mailand entworfenen Produkten – eine umfangreiche Serie von Sesseln, Sitzen, Tischen und Beistelltischen – und dem von Kogan entworfenen System. Damit entsteht eine harmonische Einheit von Einrichtungselementen für den Außenbereich, deren gemeinsamer Nenner die visuelle Leichtigkeit und die Graphik der Formen ist.*

*La collection 2018 de Minotti dédiée à l'Outdoor est née de la volonté de donner une réelle identité aux espaces en plein air, à l'aide d'éléments confortables et flexibles et offrant une évidente continuité avec l'espace domestique. Les meubles migrent de l'intérieur vers l'extérieur, conservant leur élégance innée et leur confort, pour créer un espace de vie qui dialogue avec le contexte architectural et l'espace naturel environnant. Les frontières et les fractures entre les différents lieux sont gommées, ce qui permet l'émergence d'un paysage ininterrompu où il fait bon profiter pleinement de la vie en plein air.*

*La contribution de Marcio Kogan, l'architecte brésilien célèbre pour ses architectures aux larges baies vitrées s'ouvrant sur la nature environnante et annulant toute rupture avec l'extérieur, est exemplaire en ce sens. Adoptant un langage conceptuel inspiré par le vert luxuriant, les couleurs claires et les lignes épurées des bâtiments qui rythment les paysages de son pays d'origine, le designer, autoproclamé "the square man", a développé Quadrado, un système d'assise innovant. Cette famille est définie par des volumes et des matériaux substantiels et, en même temps, par la légèreté des bases qui semblent presque flotter. Pour un produit à la silhouette architecturale conçu pour dialoguer avec l'espace et donnant naissance à des compositions organiques, articulées et solaires.*

*Entièrement coordonnée par Rodolfo Dordoni, la collection Outdoor 2018 associe des objets conçus par le designer milanais - une série de fauteuils, de chaises et de tables de différentes tailles - au système imaginé par Kogan. Pour un ensemble harmonieux dédié aux espaces extérieurs et combinant légèreté visuelle et graphisme des formes.*

## QUADRADO

Marcio Kogan / studio mk27 design

Quadrado seating system, armchair, coffee tables,  
candle holder and trays  
Duchamp "Outdoor" coffee tables







Quadrado central elements / Duchamp coffee table





Quadrado seating system, coffee tables, cushion,  
candle holders and tray  
Duchamp "Outdoor" coffee tables



Quadrado seating system, armchair, coffee tables, cushions, candle holders and trays / Prince "Cord" Outdoor armchair and footstool  
 Duchamp "Outdoor" coffee tables / Leger "Outdoor" coffee table / Warren "Outdoor" coffee table / Cesar "Outdoor" coffee table





PRINCE  
CORD  
OUTDOOR

Rodolfo Dordoni design

Prince "Cord" Outdoor armchair and footstool  
Duchamp coffee tables



DUCHAMP  
OUTDOOR  
Rodolfo Dordoni design



LEGER  
OUTDOOR  
Rodolfo Dordoni design



## VAN DYCK OUTDOOR

Rodolfo Dordoni design

Van Dyck "Outdoor" table  
York "Cord" Outdoor little armchairs



YORK CORD  
OUTDOOR  
Rodolfo Dordoni design





2018 / TECHNICAL DATA

## ALEXANDER seating system *Rodolfo Dordoni design*

### UN SISTEMA DI SEDUTE CON DIVERSE MORFOLOGIE | A SEATING SYSTEM WITH A DYNAMIC MORPHOLOGY

Ispirato a concetti razionalisti e contemporanei, Alexander è un sistema di sedute con diverse morfologie abbinabili tra loro. In una stessa composizione si possono utilizzare elementi squadrati ed elementi curvi per creare angoli raccolti e avvolgenti. Grazie ai diversi moduli combinabili tra loro si ottengono configurazioni a "L" dalla perfetta geometria o versioni lineari che possono evolvere in profili sinuosi proprio grazie agli originali elementi curvi Alexander "Drop", come la chaise-longue o gli elementi terminali con angolo arrotondato.

Inspired by rationalist and contemporary concepts, Alexander is a seating system with different forms that can be combined with each other. Squared and curved elements can be used together in the same composition to create areas with an intimate and enveloping atmosphere.

The various modular elements allow for a wide range of arrangements, from L-shaped configurations characterised by the perfect geometry to linear interpretations that can evolve into sinuous profiles thanks to the original Alexander "Drop" curved elements, such as the chaise-longue or the rounded corner elements.

Alexander, inspiriert von rationalistischen, zeitgemäßen Konzepten, bietet ein Sitzprogramm mit verschiedenen Morphologien, die untereinander kombiniert werden können. In derselben Komposition können eckige und gebogene Elemente verwendet werden, um gemütliche, stimmungsvolle Zonen zu schaffen.

Mit den zusammenpassenden Modulen können perfekt geometrische Kompositionen in "L"-Form gebildet werden, oder lineare Versionen, die sich in fließende Formen auflösen, dank der originellen, gebogenen Elemente Alexander "Drop", wie die Chaise-longue oder die Endelemente mit abgerundeten Ecken.

Inspiré de concepts rationalistes et contemporains, Alexander est un système de sièges de différentes formes, carrées et courbées, pouvant être combinées les unes avec les autres pour créer des îlots à l'atmosphère intime et enveloppante.

Les différents éléments modulables permettent une large gamme d'arrangements: en forme de L pour une géométrie rigoureuse ou en ligne droite terminée par une courbe sinuose grâce aux éléments incurvés Alexander "Drop", tels que la chaise-longue et les éléments d'angle arrondis.

### BRACCIOLI E SCHIENALI | ARMRESTS AND BACKRESTS

I moduli possono avere schienali alti, bassi o entrambi, contribuendo alla versatilità del sistema. Gli elementi con gli schienali alti disegnano punti alcova, creando angoli di intimità, dove accomodarsi come in un nido di grande comfort per leggere o guardare la tv, e si congiungono a elementi con schienali più bassi, concepiti per non ostruire la vista sullo spazio circostante.

The modules can have high or low backrests, or a combination of both, contributing to the versatility of the system. The pieces with higher backrests design alcove points, creating corners of intimacy, where to sit as in a nest of great comfort to read or watch TV. Instead, the elements with lower backrests are designed not to obstruct the view of the surrounding space.

Die Module können hohe oder niedrige Rückenlehnen haben oder beide, so dass das System extrem vielseitig wird. Die Elemente mit hoher Rückentlehne bilden kleine, alkoventartige Nischen, intime Zonen, wo man sich, wie in ein gemütliches Nest zum Lesen oder Fernsehen zurückziehen kann. Sie lassen sich mit Elementen mit niedrigerer Lehne verbinden, die den Blick auf den umgebenden Raum frei lassen.

Chaque module peut être agrémenté d'un dossier haut ou bas, ou une combinaison des deux, ce qui contribue à la versatilité du système. Les éléments au haut dossier permettent de créer des espaces intimes en alcôve où se lover comme dans un nid très confortable pour lire ou regarder la télévision. Les dossiers bas quant à eux permettent de ne pas obstruer la vue sur l'espace environnant.



ELEMENTO LOW  
LOW ELEMENT



ELEMENTO HIGH  
HIGH ELEMENT



ELEMENTO MIX  
MIX ELEMENT



SCHIENALI E BRACCIOLI BASSI  
LOW BACKRESTS AND ARMRESTS

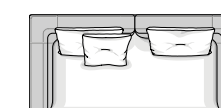

SCHIENALI E BRACCIOLI ALTI  
HIGH BACKRESTS AND ARMRESTS

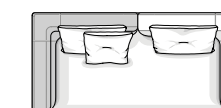

SCHIENALI E BRACCIOLI ALTI E BASSI  
HIGH AND LOW BACKRESTS/ARMRESTS

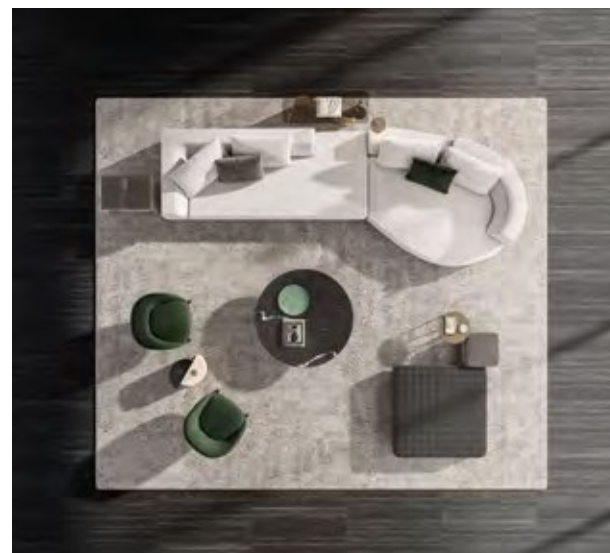
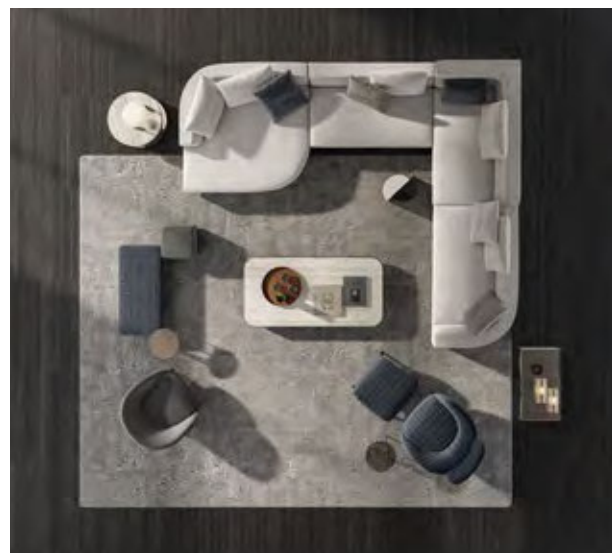

ALEXANDER  
BRACCIOLO/SCHIENALE | ARMREST/BACKREST

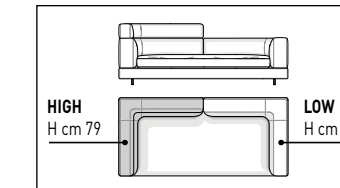

ALEXANDER "DROP"  
BRACCIOLO/SCHIENALE | ARMREST/BACKREST

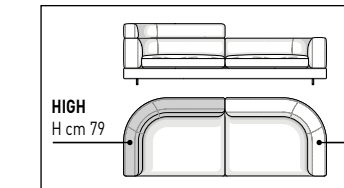

## DETTAGLI SARTORIALI | SARTORIAL DETAILS

Alexander è connotato dai dettagli sartoriali dati dalle cuciture sull'angolo del divano e sullo schienale/bracciolo alto e dalla cucitura centrale posta sui cuscini schienale.

La base è costituita da barre in alluminio color Bronzo Chiaro e mantiene gli elementi sollevati da terra, conferendo così leggerezza ai volumi sospesi.

Alexander is characterised by the sartorial details of the seams on the corner of the sofa and on the high back/armrest and by the central seam placed on the back cushions.

The base is made of Light Bronze-coloured aluminium bars and keeps the elements raised from the ground, thus conveying a sense of lightness to the suspended volumes.

Alexander zeichnet sich durch die schneiderischen Details der Nähte an der Ecke des Sofas aus, an der hohen Rücken-/Armlehne und auf der Mitte der Rückenkissen.

Die Basis besteht aus hellbronzefarbenen Aluminiumstangen, die die Elemente vom Boden abheben und so den Volumen schwebende Leichtigkeit verleihen.

Alexander est défini par ses détails empruntés au monde de la mode: les coutures sur le coin du canapé et sur le haut dossier/accoudoir et la couture centrale sur les coussins de dossier.

Le piètement est fait de barres en aluminium de couleur Bronze Clair qui gardent les éléments soulevés du sol donnant une impression de légèreté aux volumes suspendus.



## ALEXANDER *Rodolfo Dordoni design*

### DIVANI | SOFAS

DIVANO LOW CM 229  
SOFA LOW CM 229

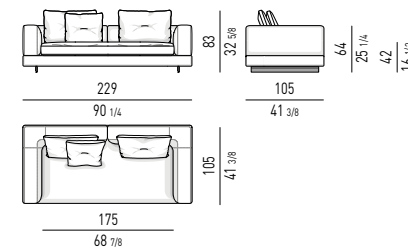

DIVANO LOW CM 254  
SOFA LOW CM 254

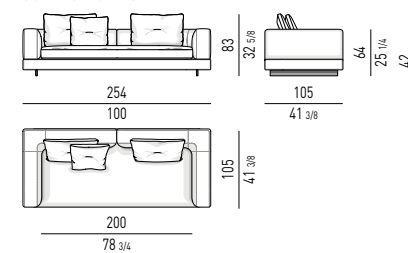

DIVANO LOW CM 274  
SOFA LOW CM 274

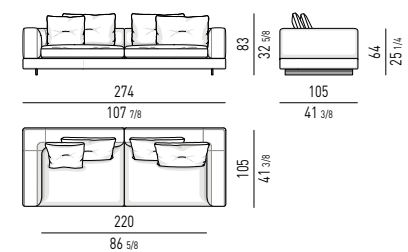

DIVANO LOW CM 304  
SOFA LOW CM 304

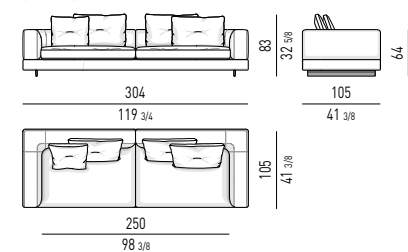

DIVANO HIGH CM 229  
SOFA HIGH CM 229

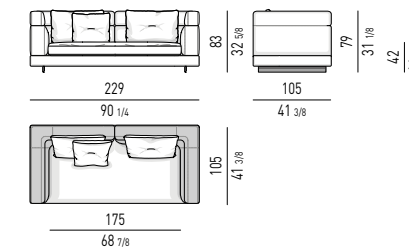

DIVANO HIGH CM 254  
SOFA HIGH CM 254

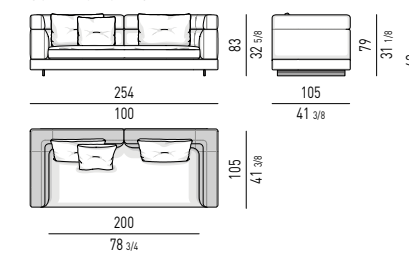

DIVANO HIGH CM 274  
SOFA HIGH CM 274

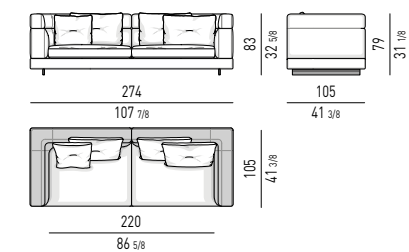

DIVANO HIGH CM 304  
SOFA HIGH CM 304

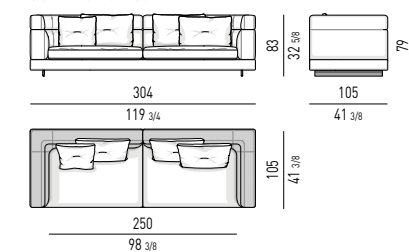

DIVANO MIX CM 229  
SOFA MIX CM 229

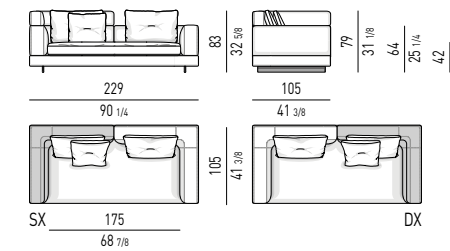

DIVANO MIX CM 254  
SOFA MIX CM 254

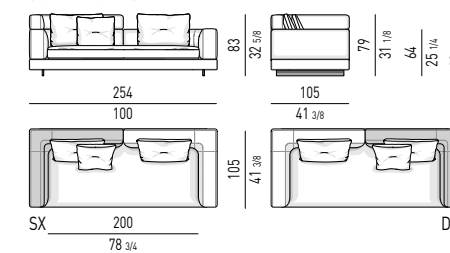

DIVANO MIX CM 274  
SOFA MIX CM 274

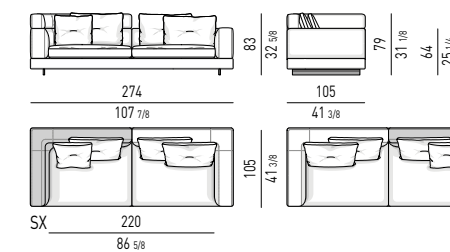

DIVANO MIX CM 304  
SOFA MIX CM 304

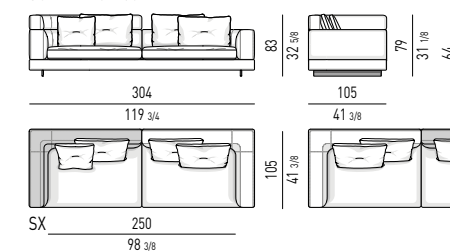

## ELEMENTI TERMINALI | ELEMENTS WITH ONE ARMREST

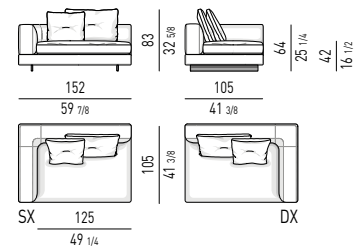
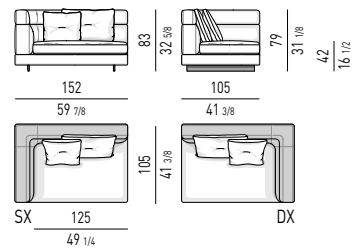
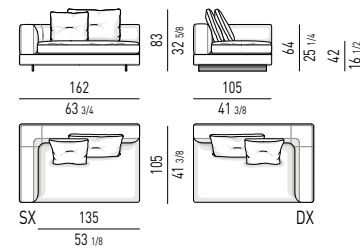
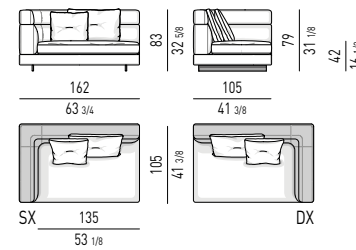
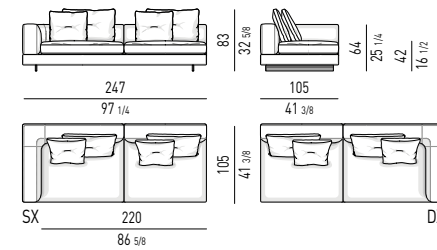
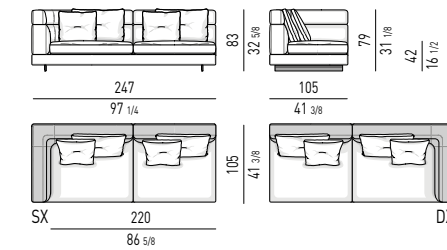
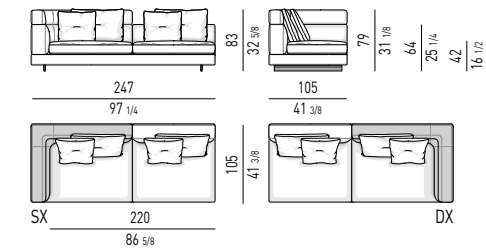
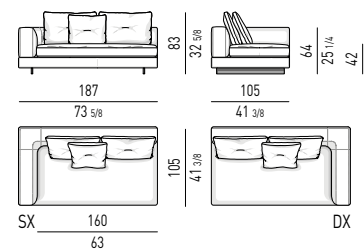
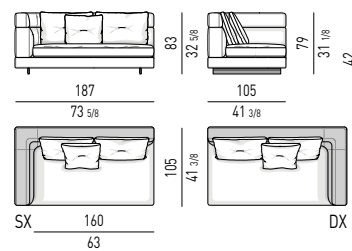
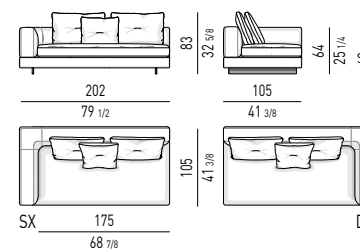
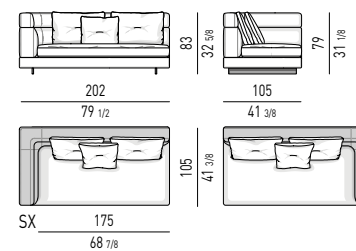
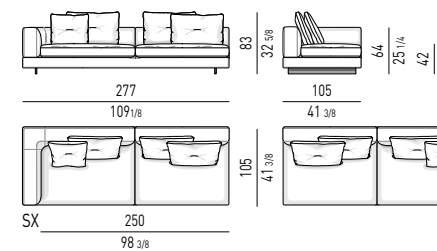
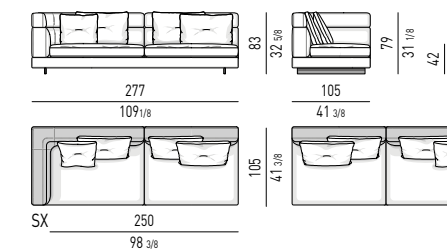
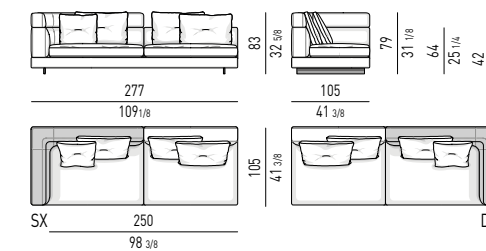
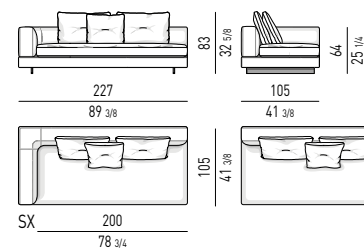
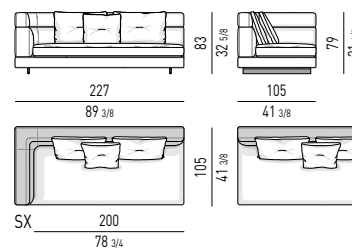
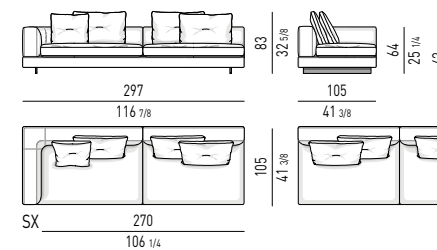
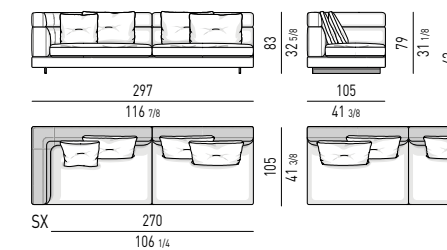
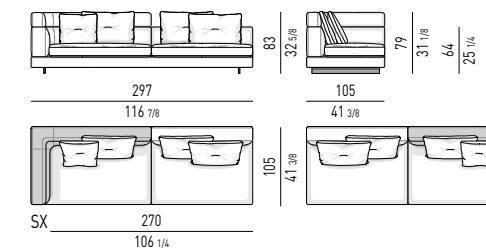
ELEMENTO TERMINALE **LOW CM 152**  
ELEMENT WITH ONE ARMREST **LOW CM 152**ELEMENTO TERMINALE **HIGH CM 152**  
ELEMENT WITH ONE ARMREST **HIGH CM 152**ELEMENTO TERMINALE **LOW CM 162**  
ELEMENT WITH ONE ARMREST **LOW CM 162**ELEMENTO TERMINALE **HIGH CM 162**  
ELEMENT WITH ONE ARMREST **HIGH CM 162**ELEMENTO TERMINALE **LOW CM 247**  
ELEMENT WITH ONE ARMREST **LOW CM 247**ELEMENTO TERMINALE **HIGH CM 247**  
ELEMENT WITH ONE ARMREST **HIGH CM 247**ELEMENTO TERMINALE **MIX CM 247**  
ELEMENT WITH ONE ARMREST **MIX CM 247**ELEMENTO TERMINALE **LOW CM 187**  
ELEMENT WITH ONE ARMREST **LOW CM 187**ELEMENTO TERMINALE **HIGH CM 187**  
ELEMENT WITH ONE ARMREST **HIGH CM 187**ELEMENTO TERMINALE **LOW CM 202**  
ELEMENT WITH ONE ARMREST **LOW CM 202**ELEMENTO TERMINALE **HIGH CM 202**  
ELEMENT WITH ONE ARMREST **HIGH CM 202**ELEMENTO TERMINALE **LOW CM 277**  
ELEMENT WITH ONE ARMREST **LOW CM 277**ELEMENTO TERMINALE **HIGH CM 277**  
ELEMENT WITH ONE ARMREST **HIGH CM 277**ELEMENTO TERMINALE **MIX CM 277**  
ELEMENT WITH ONE ARMREST **MIX CM 277**ELEMENTO TERMINALE **LOW CM 227**  
ELEMENT WITH ONE ARMREST **LOW CM 227**ELEMENTO TERMINALE **HIGH CM 227**  
ELEMENT WITH ONE ARMREST **HIGH CM 227**ELEMENTO TERMINALE **LOW CM 297**  
ELEMENT WITH ONE ARMREST **LOW CM 297**ELEMENTO TERMINALE **HIGH CM 297**  
ELEMENT WITH ONE ARMREST **HIGH CM 297**ELEMENTO TERMINALE **MIX CM 297**  
ELEMENT WITH ONE ARMREST **MIX CM 297**

ELEMENTI CENTRALI | CENTRAL ELEMENTS

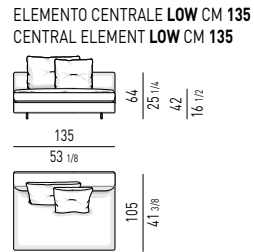
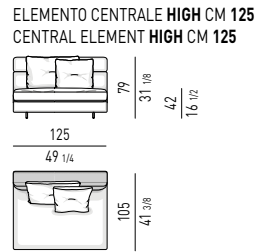
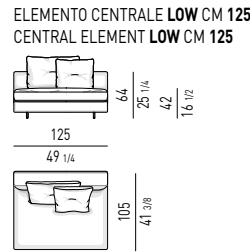
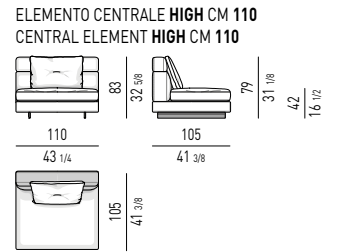
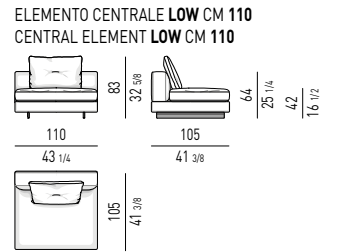

ELEMENTI PENISOLA | OPEN-END ELEMENTS

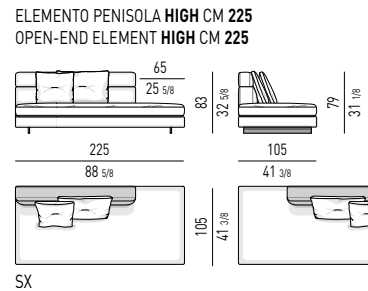
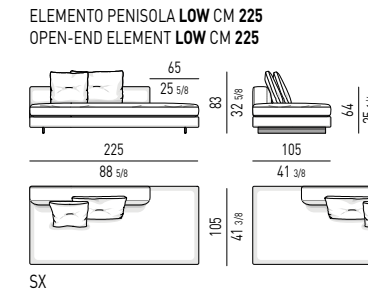
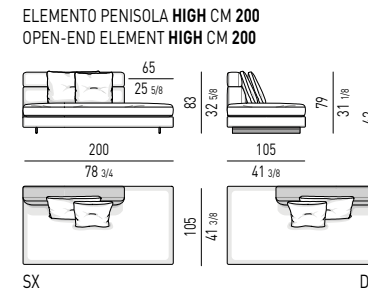
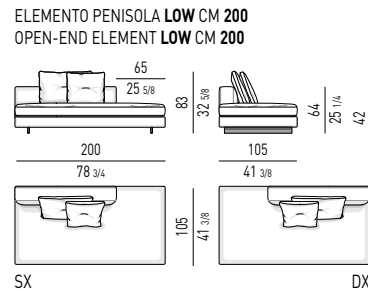
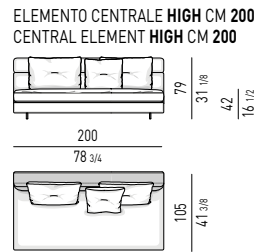
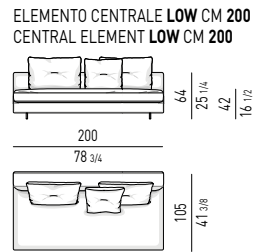
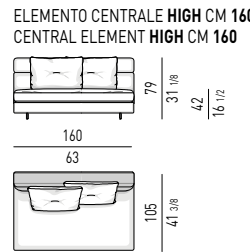
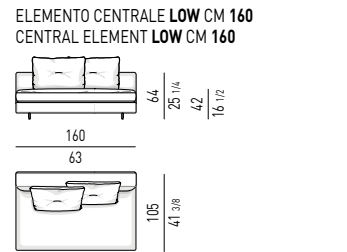
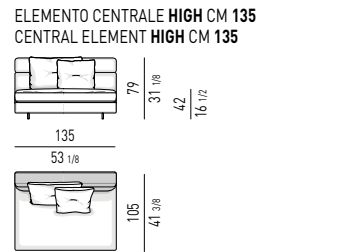
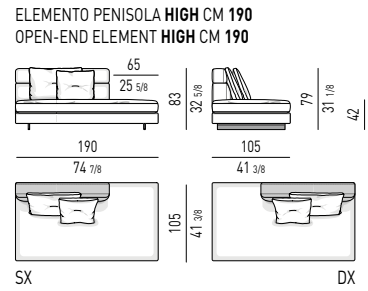
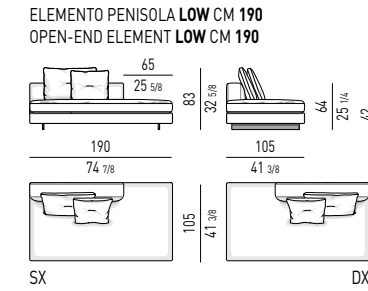
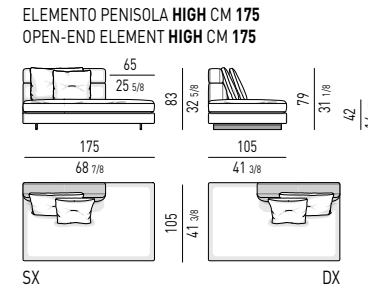
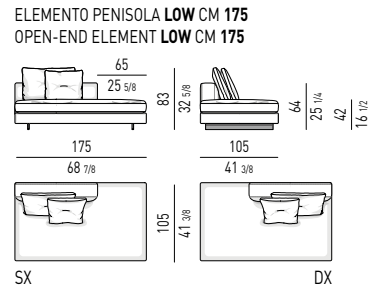

ELEMENTI TERMINALI PENISOLA | OPEN-END ELEMENTS WITH ONE ARMREST

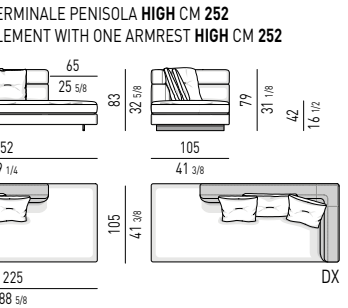
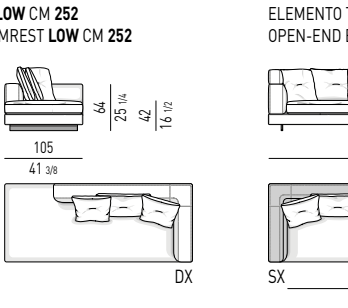
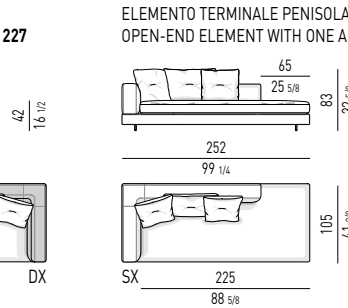
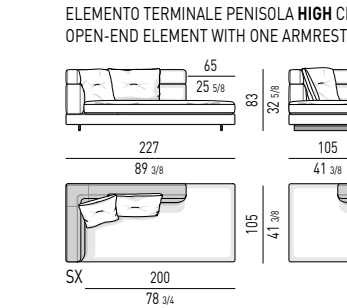
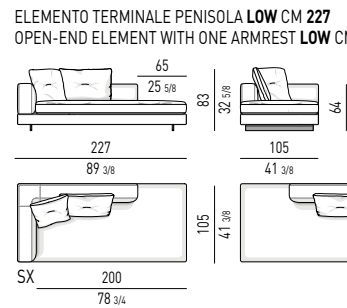
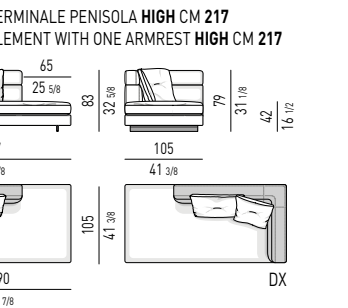
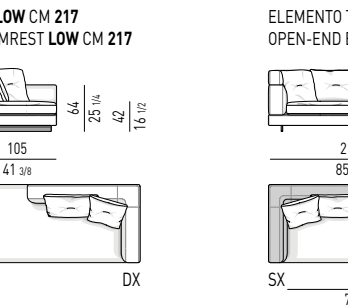
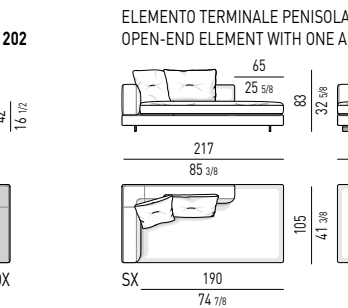
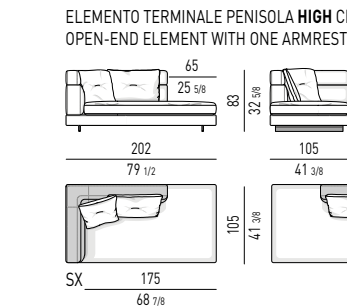
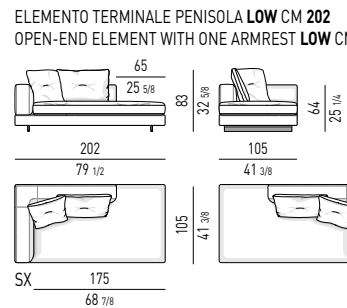

**COUCHES**

**COUCH LOW CM 105x187**  
**COUCH LOW CM 105x187**

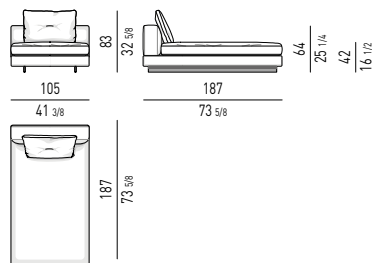

**COUCH HIGH CM 105x187**  
**COUCH HIGH CM 105x187**

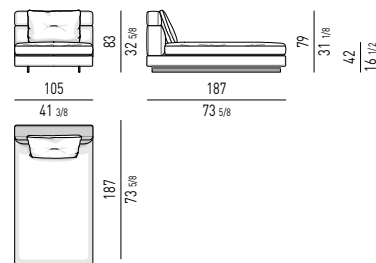

**CHAISE-LONGUES**

**CHAISE-LONGUE LOW CM 162x162**  
**CHAISE-LONGUE LOW CM 162x162**

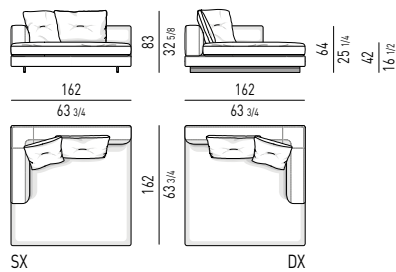

**CHAISE-LONGUE HIGH CM 162x162**  
**CHAISE-LONGUE HIGH CM 162x162**

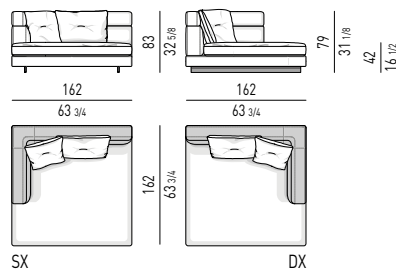

**CHAISE-LONGUE LOW CM 105x162**  
**CHAISE-LONGUE LOW CM 105x162**

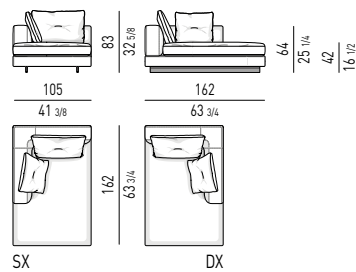

**CHAISE-LONGUE HIGH CM 105x162**  
**CHAISE-LONGUE HIGH CM 105x162**

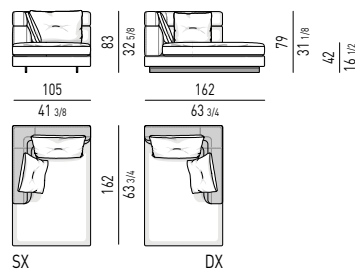

**POUF CM 105x105**  
**OTTOMAN CM 105x105**

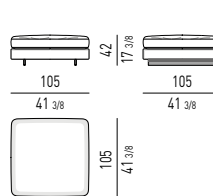

**CUSCINI SCHIENALE OPTIONAL**  
**OPTIONAL BACK CUSHIONS**

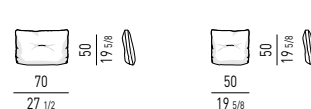

**POGGIATESTA OPTIONAL**  
**OPTIONAL HEADREST**

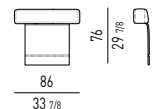

**CUSCINO OPTIONAL TEDDY**  
**OPTIONAL CUSHION**

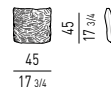

**POSIZIONE POGGIATESTA | HEADREST POSITION**

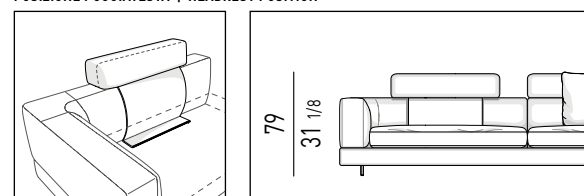

**FINITURA BASE**  
**BASE FINISH**

**ALLUMINIO | ALUMINUM**

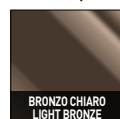

**ALEXANDER "DROP" Rodolfo Dordoni design**

**DIVANI | SOFAS**

**DIVANO LOW CM 274**  
**SOFA LOW CM 274**

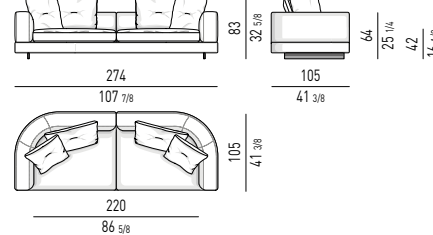

**DIVANO HIGH CM 274**  
**SOFA HIGH CM 274**

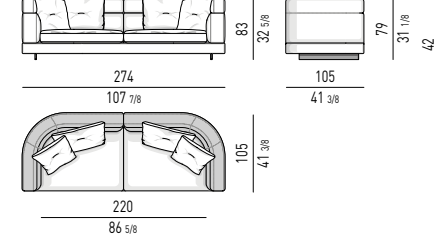

**DIVANO MIX CM 274**  
**SOFA MIX CM 274**

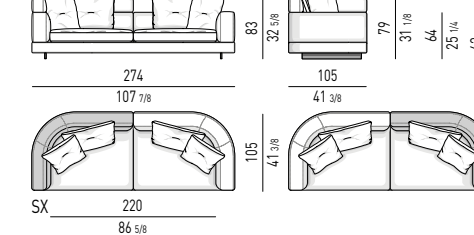

**DIVANO LOW CM 304**  
**SOFA LOW CM 304**

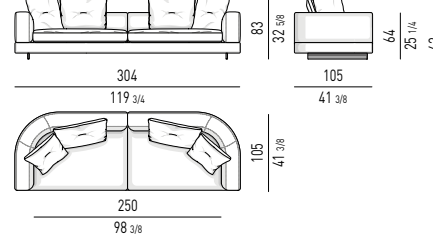

**DIVANO HIGH CM 304**  
**SOFA HIGH CM 304**

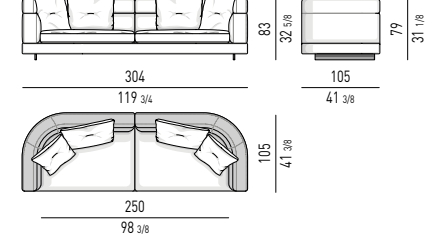

**DIVANO MIX CM 304**  
**SOFA MIX CM 304**

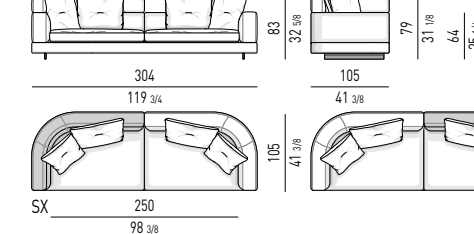

**ELEMENTI TERMINALI | ELEMENTS WITH ONE ARMREST**

**ELEMENTO TERMINALE LOW CM 162**  
**ELEMENT WITH ONE ARMREST LOW CM 162**

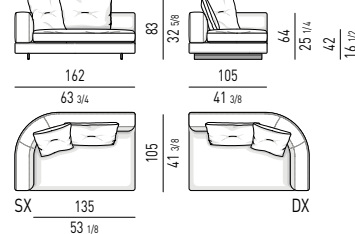

**ELEMENTO TERMINALE HIGH CM 162**  
**ELEMENT WITH ONE ARMREST HIGH CM 162**

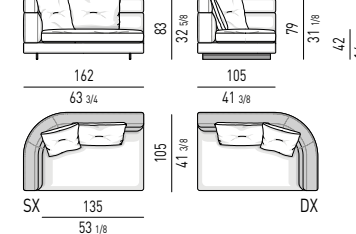

**ELEMENTO TERMINALE LOW CM 187**  
**ELEMENT WITH ONE ARMREST LOW CM 187**

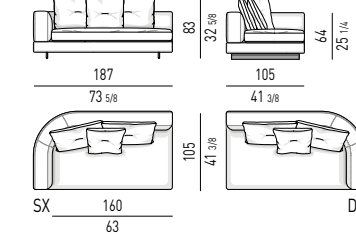

**ELEMENTO TERMINALE HIGH CM 187**  
**ELEMENT WITH ONE ARMREST HIGH CM 187**

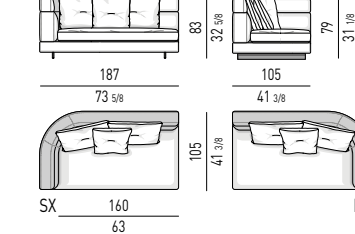

**ELEMENTO TERMINALE LOW CM 202**  
**ELEMENT WITH ONE ARMREST LOW CM 202**

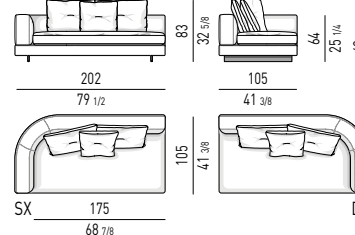

**ELEMENTO TERMINALE HIGH CM 202**  
**ELEMENT WITH ONE ARMREST HIGH CM 202**

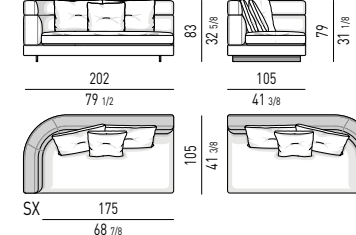

**ELEMENTO TERMINALE LOW CM 227**  
**ELEMENT WITH ONE ARMREST LOW CM 227**

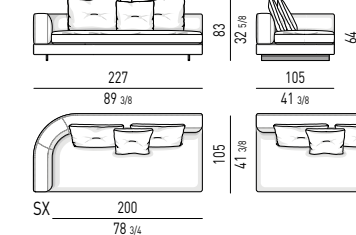

**ELEMENTO TERMINALE HIGH CM 227**  
**ELEMENT WITH ONE ARMREST HIGH CM 227**

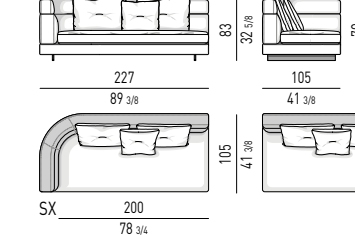

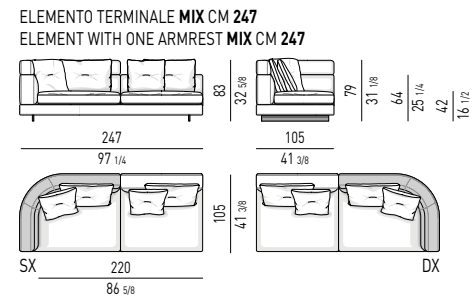
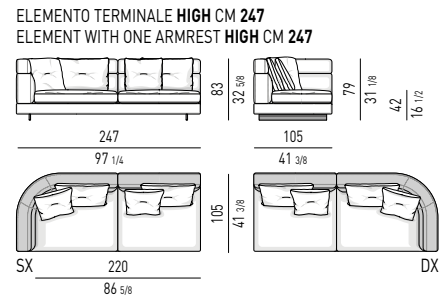
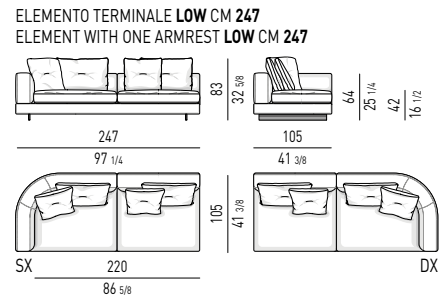

**ELEMENTI TERMINALI "RAY" | "RAY" ELEMENTS WITH ONE ARMREST**

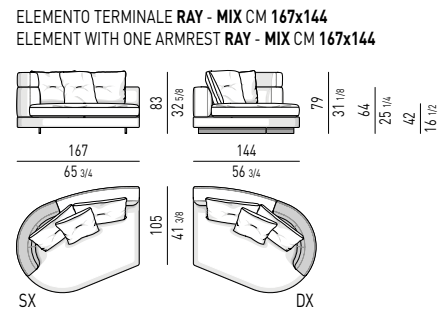
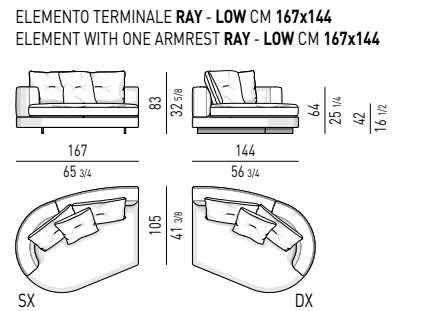

**ELEMENTI TERMINALI PENISOLA | OPEN-END ELEMENTS WITH ONE ARMREST**

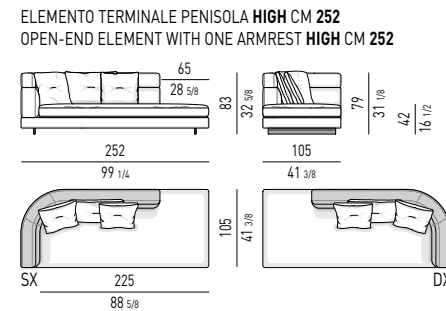
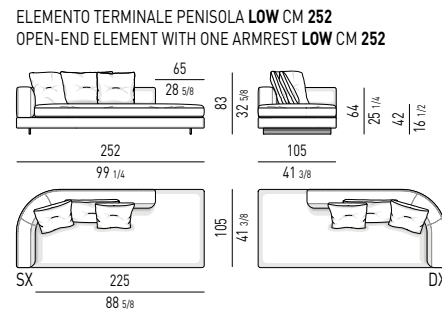
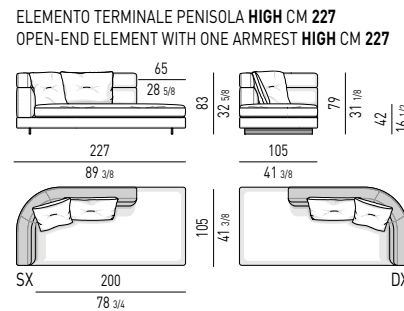
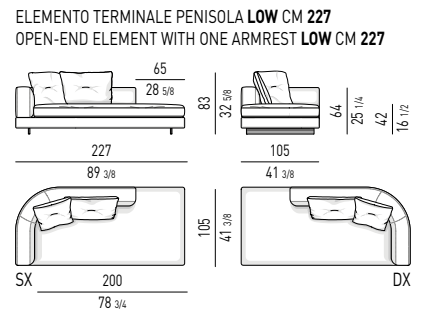

**CHAISE-LONGUES**

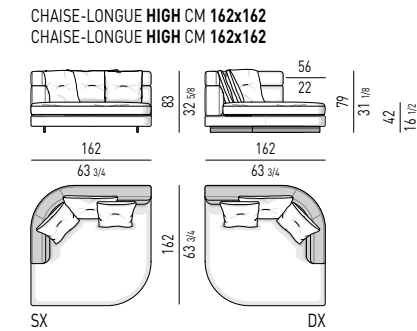
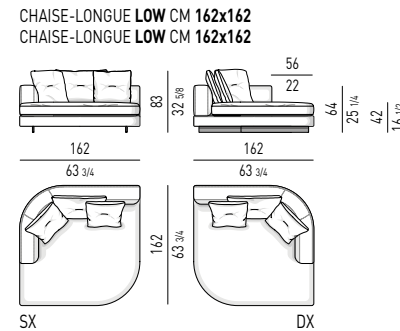

**CHAISE-LONGUES "RAY"**

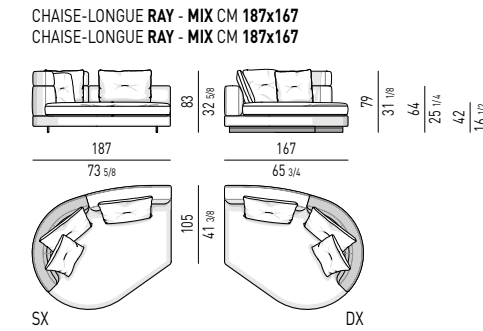
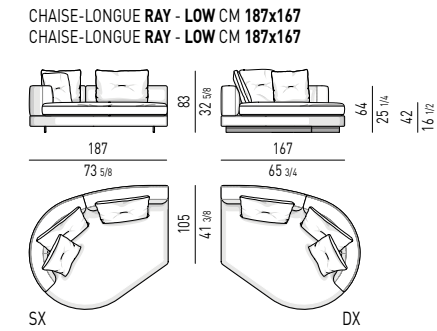

**CUSCINI SCHIENALE OPTIONAL**  
**OPTIONAL BACK CUSHIONS**

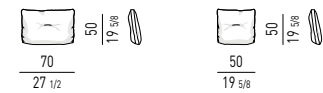

**POGGIATESTA OPTIONAL**  
**OPTIONAL HEADREST**

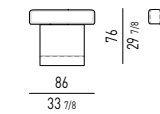

**CUSCINO OPTIONAL TEDDY**  
**TEDDY OPTIONAL CUSHION**

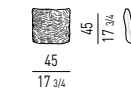

**POSIZIONE POGGIATESTA | HEADREST POSITION**

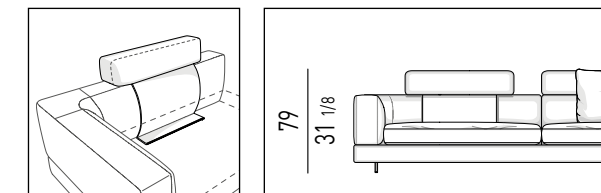

**FINITURA BASE**  
**BASE FINISH**

**ALLUMINIO | ALUMINUM**

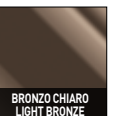

## GRANVILLE seating system *Christophe Delcourt design*

### UN NUOVO CONCETTO DI COMFORT | A NEW CONCEPT OF COMFORT

Il sistema di sedute Granville è frutto di un'attenta ricerca sulla forma libera: il progetto è incentrato su un gioco di curve, di tratti marcati e leggeri. I moduli, diversi per forma e dimensioni, dialogano tra loro e si completano a vicenda, mentre i braccioli e gli schienali definiscono articolate zone relax, offrendo modalità differenti di seduta.

Granville si presenta sia come sistema divano nell'accezione più tradizionale, sia in una veste più flessibile e articolata di isole aggregabili tra loro, prive di schienali e braccioli fissi, ma dotabili di uno schienale amovibile, con una forma curva originale.

Perché Granville non è un semplice lavoro formale, ma l'occasione per riflettere sul divano come spazio da vivere e condividere, espressione di uno spirito giovane e contemporaneo. Così, lo spessore dello schienale, l'aggiunta di un elemento chaise-longue, la presenza o l'assenza di braccioli sono un invito a vivere il divano in modi diversi, a seconda del numero degli ospiti, delle proprie esigenze, del momento della giornata.

Un sistema che offre un nuovo concetto di comfort e ridisegna il paesaggio del living.

A result of the careful research on the free-form, the Granville seating system focuses on a game of curves and of marked and light strokes. The modules, which vary in shape and size, interact with each other, while the armrests and backrests define articulated relaxation areas with different seating modes.

Granville is available both in the traditional sofa option and as a more flexible and articulated solution of detached islands. Joinable together, the various elements come without fixed backrests and armrests and are characterised by the original curved shape of the removable backrest.

Developed not as a simple formal exercise, but instead as an opportunity to reflect on the sofa as a space to be lived and shared, Granville is the expression of a young and contemporary spirit. The thickness of the backrest, together with the addition of a chaise-longue element and the detachable armrests are an invitation to live it in different ways, depending on the number of guests, their needs, or the time of the day.

A system that offers a new concept of comfort and that redesigns the living room landscape.

Das Sitzprogramm ist Ergebnis einer akkuraten Analyse der freien Form: Im Mittelpunkt des Projekts steht ein Spiel mit Kurven, mit stark markierten und schwerelosen Linien. Die Module, mit verschiedenen Formen und Dimensionen, verbinden und ergänzen sich gegenseitig, während die Arm- und Rückenlehnen spezifische Entspannungszonen definieren, indem sie zu unterschiedlichen Sitzpositionen einladen.

Granville präsentiert sich als ein Sofa-Programm in absolut traditionellem Sinn, oder aber in einer flexibleren Form, untergliedert in, untereinander kombinierbare Inseln, ohne feste Rücken- und Armlehnen, aber mit einer abnehmbaren Rückenlehne in originell gekrümmter Form.

Granville beinhaltet nicht einfach nur den Entwurf einer Form, sondern die Möglichkeit, das Sofa als eine Zone zu konzipieren, die gelebt und geteilt werden will, Ausdruck einer jungen, modernen Mentalität. Und so werden die Dicke der Rückenlehne, eine hinzugefügte Chaiselongue, die Präsenz oder das Fehlen von Armlehnen eine Einladung, das Sofa auf verschiedene Weise zu leben, je nach der Anzahl der Gäste, der eigenen Erfordernisse oder der Tageszeit.

Ein Programm, das ein neues Konzept des Komforts bietet und unsere Wohnlandschaft neugestaltet.

Fruit d'une recherche minutieuse autour de la forme libre, le système d'assise Granville s'exprime par un jeu de courbes et de lignes légères et décidées. Les modules, qui varient en forme et en taille, interagissent les uns avec les autres, tandis que les accoudoirs et les dossiers définissent des zones de relaxation articulées offrant différentes utilisations.

Granville est disponible en canapé traditionnel ainsi que dans une forme plus flexible composée d'îlots détachés et modulables sans dossiers et accoudoirs - mais pouvant être équipés d'un dossier amovible à la forme incurvée originale.

Plus qu'un simple exercice formel, Granville est l'expression d'un esprit jeune et contemporain au sein duquel le canapé joue le rôle d'espace de partage. L'épaisseur du dossier, l'ajout d'un élément lounge et les accoudoirs amovibles sont autant d'invitations à la vivre différemment au gré de ses besoins, selon le nombre d'invités ou l'heure de la journée. Un système qui présente un nouveau concept de confort et qui redessine le paysage du salon.



#### ELEMENTI CENTRALI - PROFONDITÀ CM 95 CENTRAL ELEMENTS - DEPTH CM 95

##### ELEMENTO CENTRALE CM 144 CENTRAL ELEMENT CM 144

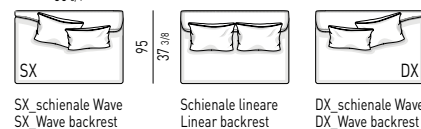
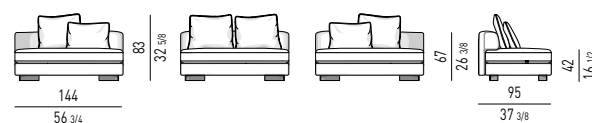

##### ELEMENTO CENTRALE CM 174 CENTRAL ELEMENT CM 174

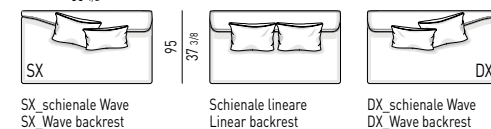
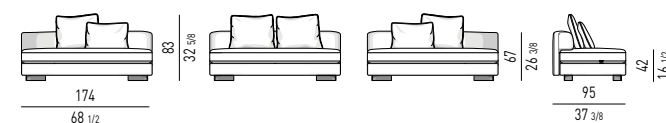

#### ELEMENTO CENTRALE - PROFONDITÀ CM 110 CENTRAL ELEMENT - DEPTH CM 110

##### ELEMENTO CENTRALE CM 103 CENTRAL ELEMENT CM 103

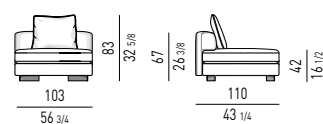

##### ELEMENTO CENTRALE CM 144 CENTRAL ELEMENT CM 144

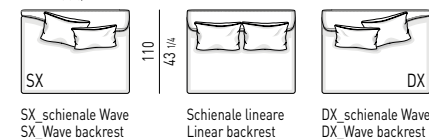
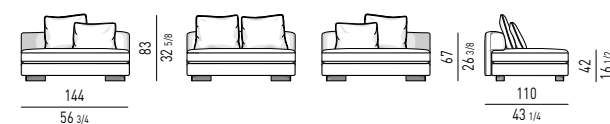

##### ELEMENTO CENTRALE CM 174 CENTRAL ELEMENT CM 174

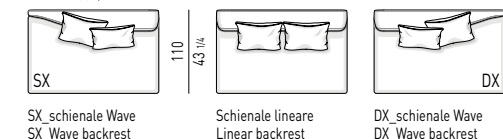
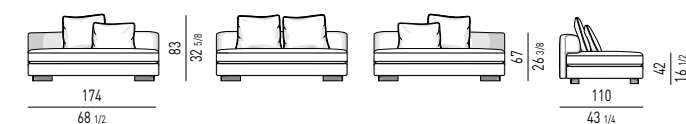

#### ELEMENTI CENTRALI INCLINATI - PROFONDITÀ CM 95/110 INCLINED CENTRAL ELEMENTS - DEPTHS CM 95/110

##### ELEMENTO CENTRALE INCLINATO CM 144 INCLINED CENTRAL ELEMENT CM 144

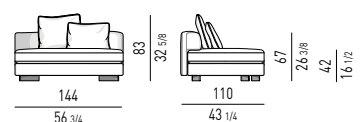

Profondità lato **SINISTRO** cm 95  
Depth **LEFT** side cm 95

Profondità lato **DESTRO** cm 95  
Depth **RIGHT** side cm 95

Profondità lato **SINISTRO** cm 110  
Depth **LEFT** side cm 110

Profondità lato **DESTRO** cm 110  
Depth **RIGHT** side cm 110

##### ELEMENTO CENTRALE INCLINATO CM 174 INCLINED CENTRAL ELEMENT CM 174

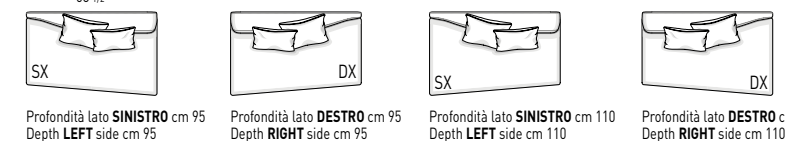
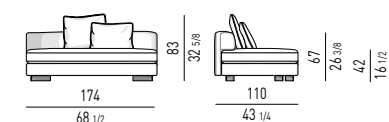

Profondità lato **SINISTRO** cm 95  
Depth **LEFT** side cm 95

Profondità lato **DESTRO** cm 95  
Depth **RIGHT** side cm 95

Profondità lato **SINISTRO** cm 110  
Depth **LEFT** side cm 110

Profondità lato **DESTRO** cm 110  
Depth **RIGHT** side cm 110



**ELEMENTI TERMINALI - PROFONDITÀ CM 95**  
**ELEMENTS WITH ONE ARMREST - DEPTH CM 95**

ELEMENTO TERMINALE CM 151  
 ELEMENT WITH ONE ARMREST CM 151

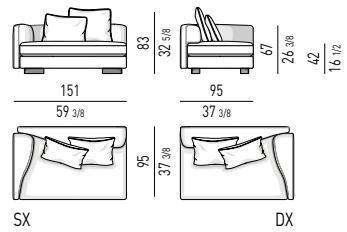

ELEMENTO TERMINALE CM 181  
 ELEMENT WITH ONE ARMREST CM 181

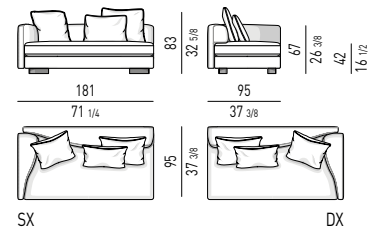

**ELEMENTI TERMINALI - PROFONDITÀ CM 110**  
**ELEMENTS WITH ONE ARMREST - DEPTH CM 110**

ELEMENTO TERMINALE CM 151  
 ELEMENT WITH ONE ARMREST CM 151

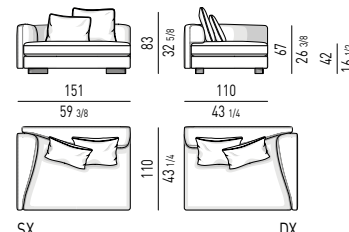

ELEMENTO TERMINALE CM 181  
 ELEMENT WITH ONE ARMREST CM 181

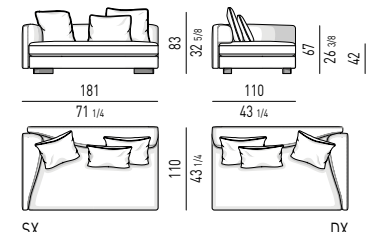

**ELEMENTI TERMINALI INCLINATI - PROFONDITÀ CM 95/110**  
**INCLINED ELEMENTS WITH ONE ARMREST - DEPTHS CM 95/110**

ELEMENTO TERMINALE **INCLINATO** CM 151  
**INCLINED** ELEMENT WITH ONE ARMREST CM 151

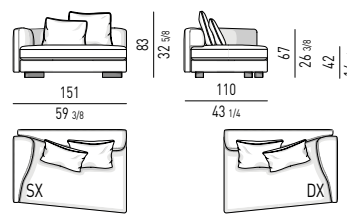

Profondità lato **SINISTRO** cm 95  
 Depth **LEFT** side cm 95



Profondità lato **DESTRO** cm 95  
 Depth **RIGHT** side cm 95

ELEMENTO TERMINALE **INCLINATO** CM 181  
**INCLINED** ELEMENT WITH ONE ARMREST CM 181

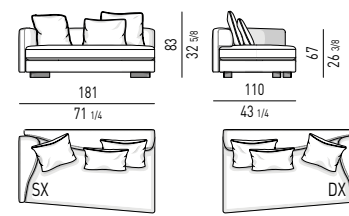

Profondità lato **SINISTRO** cm 95  
 Depth **LEFT** side cm 95



Profondità lato **DESTRO** cm 95  
 Depth **RIGHT** side cm 95

**ELEMENTI ANGOLARI - PROFONDITÀ CM 95**  
**CORNER ELEMENTS - DEPTH CM 95**

ELEMENTO ANGOLARE CM 151  
 CORNER ELEMENT CM 151

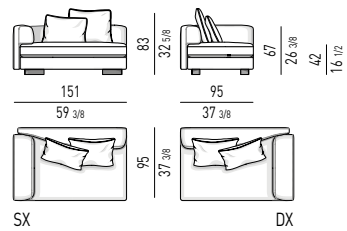

ELEMENTO ANGOLARE CM 181  
 CORNER ELEMENT CM 181

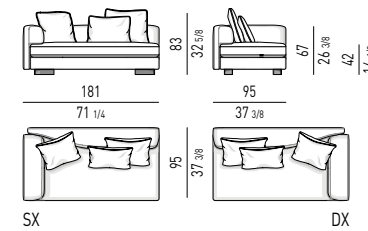

**ELEMENTI ANGOLARI - PROFONDITÀ CM 110**  
**CORNER ELEMENTS - DEPTH CM 110**

ELEMENTO ANGOLARE CM 151  
 CORNER ELEMENT CM 151

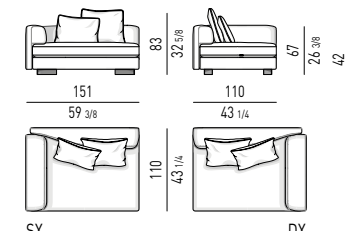

ELEMENTO ANGOLARE CM 181  
 CORNER ELEMENT CM 181

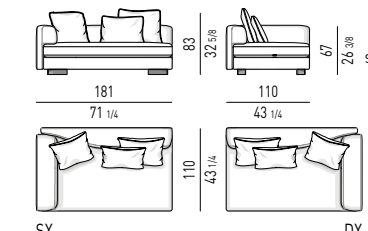

**COUCHES**

COUCH CM 88x181  
 COUCH CM 88x181

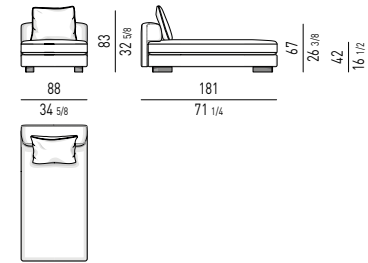

COUCH CM 103x181  
 COUCH CM 103x181

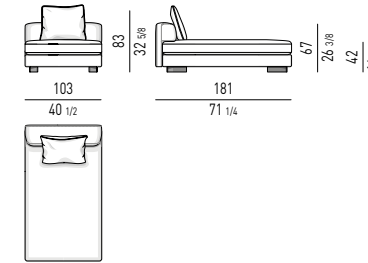

**CHAISE-LONGUES**

CHAISE-LONGUE CM 110  
 CHAISE-LONGUE CM 110

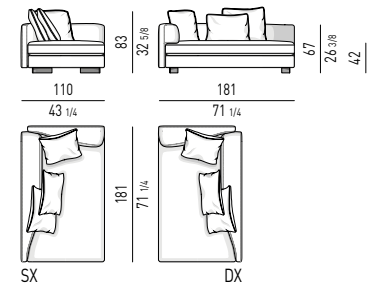

CHAISE-LONGUE CM 166  
 CHAISE-LONGUE CM 166

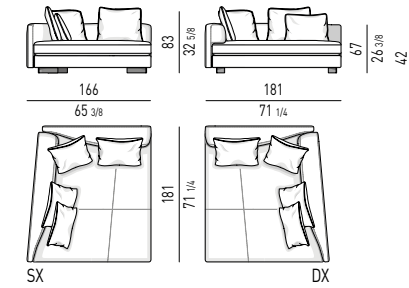

CHAISE-LONGUE CM 196  
 CHAISE-LONGUE CM 196

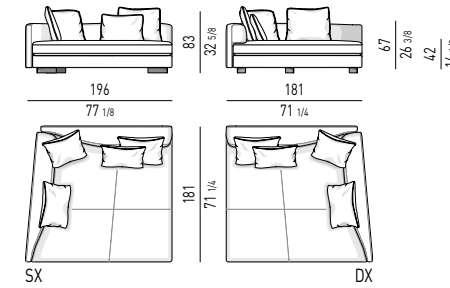

**POUF OTTOMANS**

POUF CM 144x88  
 OTTOMAN CM 144x88

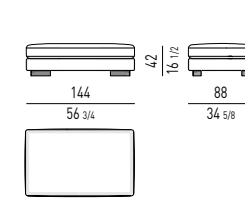

POUF CM 174x88  
 OTTOMAN CM 174x88

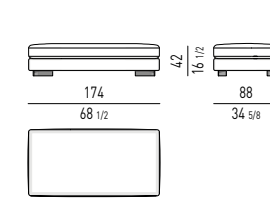

POUF CM 144x103  
 OTTOMAN CM 144x103

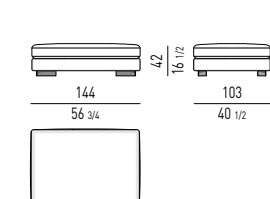

POUF CM 174x103  
 OTTOMAN CM 174x103

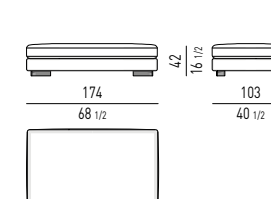



DIVANO CHAISE-LONGUE SENZA BRACCIOLO CM 188  
SOFA CHAISE-LONGUE WITHOUT ARMREST CM 188

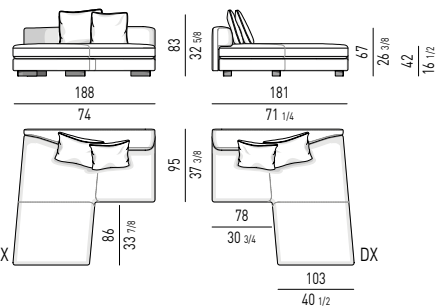

COD. 685 188x181W\_C COD. 686 158x181W\_D

DIVANO CHAISE-LONGUE SENZA BRACCIOLO CM 188  
SOFA CHAISE-LONGUE WITHOUT ARMREST CM 188

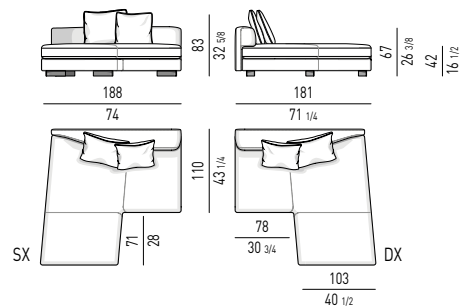

COD. 687 188x181W\_E COD. 688 188x181W\_F

ELEMENTI PANCA INCLINATI  
INCLINED BENCH ELEMENTS

ELEMENTO PANCA INCLINATA CM 144  
INCLINED BENCH ELEMENT CM 144

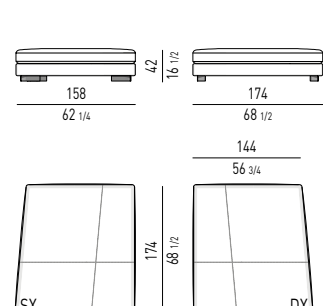

COD. 699 158x174I\_A COD. 6100 158x174I\_B

ELEMENTO PANCA INCLINATA CM 174  
INCLINED BENCH ELEMENT CM 174

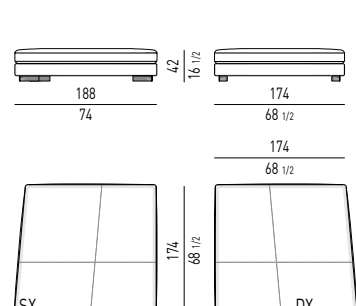

COD. 6101 188x174I\_A COD. 6102 188x174I\_B

PANCHE CHAISE-LONGUES  
BENCHES CHAISE-LONGUES

PANCA CHAISE-LONGUE CM 158  
BENCH CHAISE-LONGUE CM 158

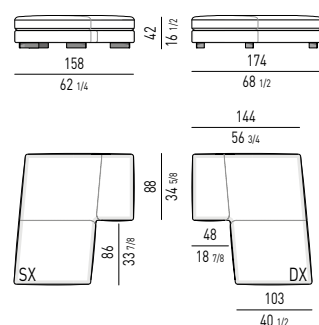

COD. 689 158x174P\_A COD. 690 158x174P\_B

PANCA CHAISE-LONGUE CM 188  
BENCH CHAISE-LONGUE CM 188

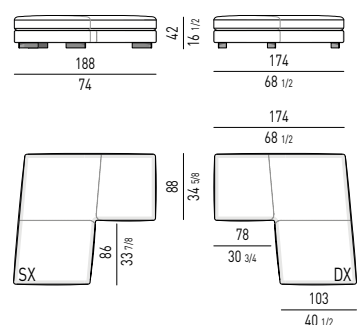

COD. 693 188x174P\_A COD. 694 188x174P\_B

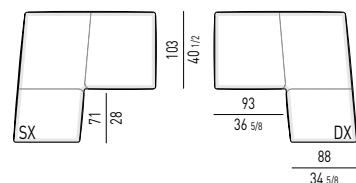

COD. 695 188x174P\_C COD. 696 188x174P\_D

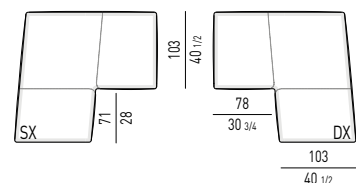

COD. 697 188x174P\_E COD. 698 188x174P\_F

POUF OTTOMAN

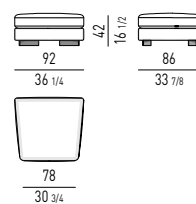

SCHIENALE AMOVIBILE OPTIONAL  
OPTIONAL REMOVABLE BACKREST

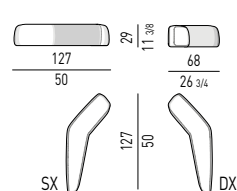

CUSCINI SCHIENALE OPTIONAL  
OPTIONAL BACK CUSHIONS

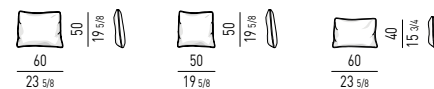

CUSCINO OPTIONAL TEDDY  
TEDDY OPTIONAL CUSHION

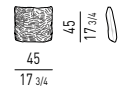

FINITURA BASE  
BASE FINISH

ALLUMINIO | ALUMINUM



RUSSELL Rodolfo Dordoni design

DIVANO CURVO | ANGLED SOFA

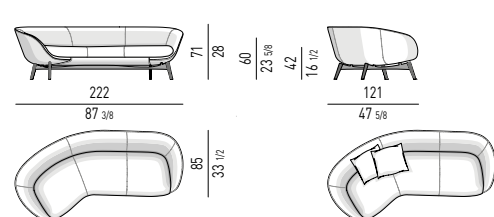

CUSCINI OPTIONAL A RICHIESTA  
OPTIONAL CUSHIONS AVAILABLE ON REQUEST

CUSCINO OPTIONAL | OPTIONAL CUSHION

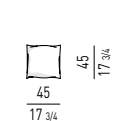

BERGÈRE  
FISSA | FIXED

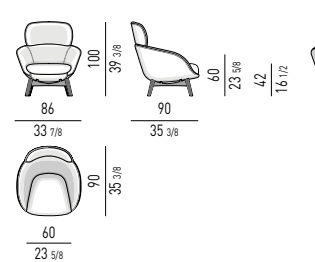

GIREVOLE | SWIVEL

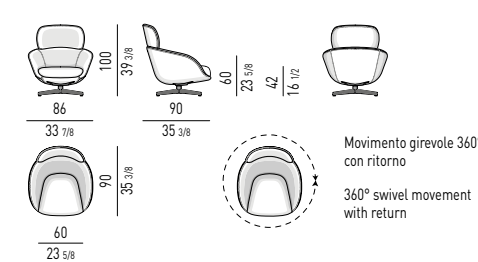

POLTRONA | ARMCHAIR  
FISSA | FIXED

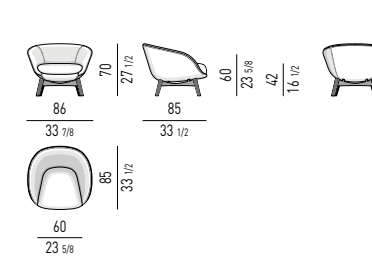

GIREVOLE | SWIVEL

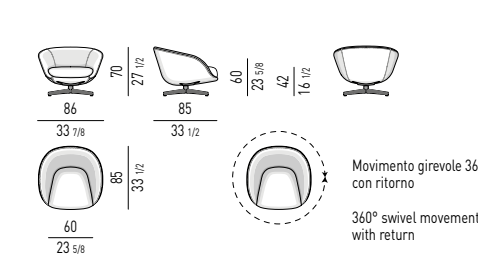

POGGIAPIEDI | "FOOTSTOOL"  
FEET BASE

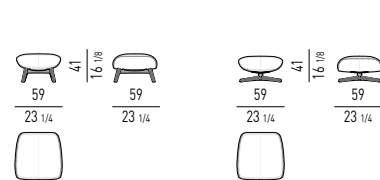

CROSS BASE

POLTRONCINA "DINING" | "DINING" LITTLE ARMCHAIR  
GIREVOLE | SWIVEL

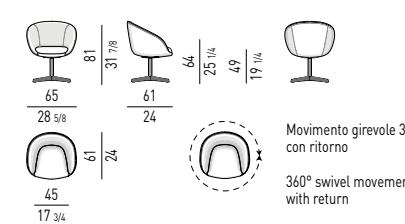

POLTRONCINA "LOUNGE" | "LOUNGE" LITTLE ARMCHAIR  
FISSA | FIXED

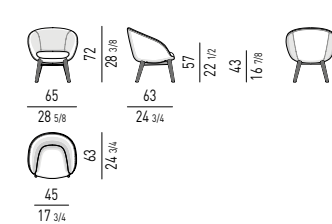

POLTRONCINA "LOUNGE" | "LOUNGE" LITTLE ARMCHAIR  
GIREVOLE | SWIVEL

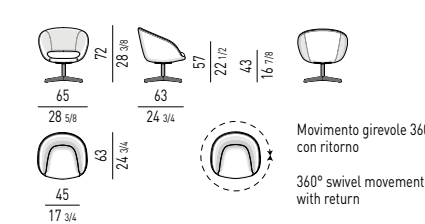

**TAPE** *nendo design*

**DIVANI | SOFAS**

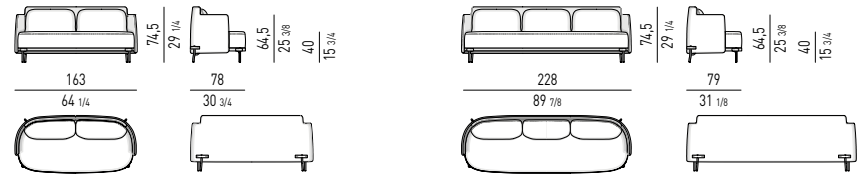

**BERGÈRE**

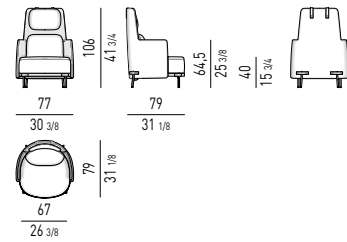

**POLTRONA | ARMCHAIR**

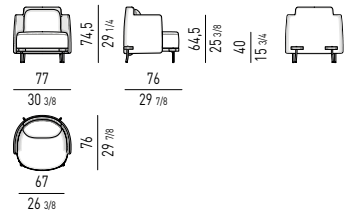

**POLTRONE SENZA BRACCIOLI | ARMCHAIRS WITHOUT ARMRESTS**

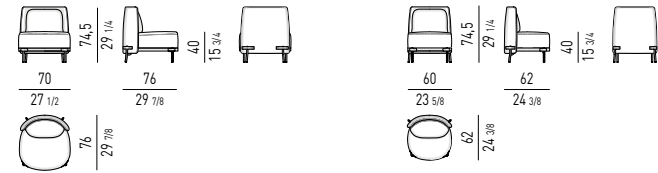

**POGGIAPIEDI | FOOTSTOOL**

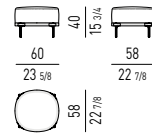

**FINITURA BASE**  
BASE FINISH

**METALLO | METAL**

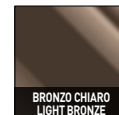

**FINITURA FASCIA IN CUOIO**  
SADDLE-HIDE TRIM FINISH

**CUOIO | SADDLE-HIDE**

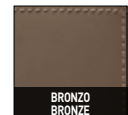

**FASCIA DECORATIVA**  
DECORATIVE TRIM

**PELLE | LEATHER**



**CUOIO | SADDLE-HIDE**



**ALBERT** *Gigi Radice design / Minotti Historic Archive*

**DIVANO LOUNGE | LOUNGE SOFA**

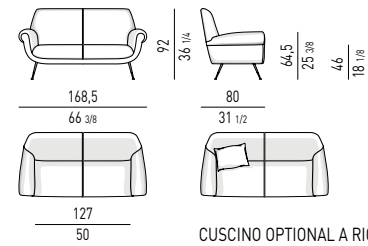

CUSCINO OPTIONAL A RICHIESTA  
OPTIONAL CUSHION AVAILABLE ON REQUEST

**DIVANO CURVO | ANGLED SOFA**

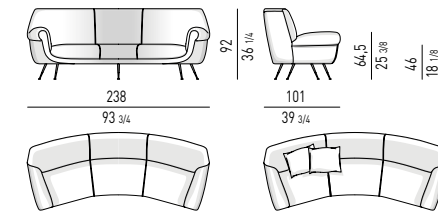

CUSCINI OPTIONAL A RICHIESTA  
OPTIONAL CUSHIONS AVAILABLE ON REQUEST

**POLTRONA | ARMCHAIR**

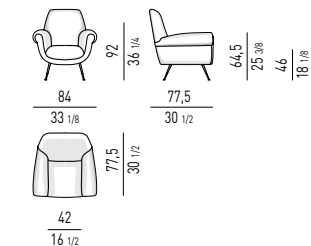

**POGGIAPIEDI | FOOTSTOOL**

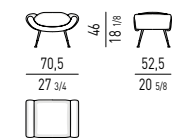

**CUSCINO OPTIONAL | OPTIONAL CUSHION**

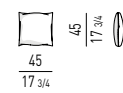

**TAVOLINO | COFFEE TABLE**

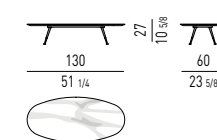

**ILE** *Gigi Radice design / Minotti Historic Archive*

**POLTRONA | ARMCHAIR**

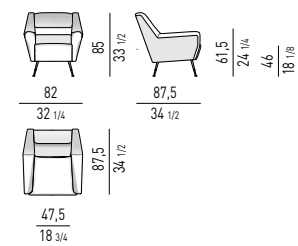

**DIVANO LOUNGE | LOUNGE SOFA**

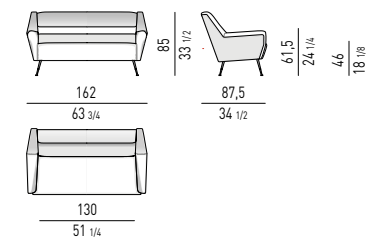

**FINITURA GAMBE**  
LEGS FINISH

**METALLO | METAL**

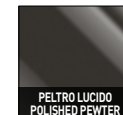

**FINITURE PUNTALE**  
TIP FINISHES

**METALLO | METAL**

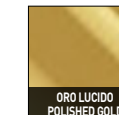

**METALLO | METAL**

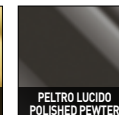

**FINITURA PIANO TAVOLINO**  
COFFEE TABLE TOP FINISH

**MARMO | MARBLE**



**PUNTALE**  
TIP

**ORO LUCIDO | POLISHED GOLD**



**PELTRO LUCIDO | POLISHED PEWTER**

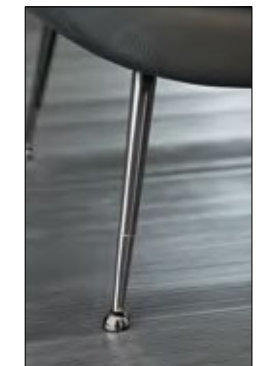

**PRINCE “CORD” INDOOR** *Rodolfo Dordoni design*

**POLTRONA | ARMCHAIR**

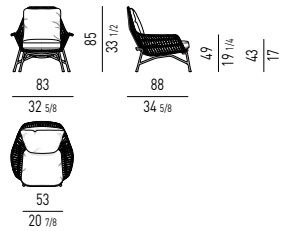

**POGGIAPIEDI | FOOTSTOOL**

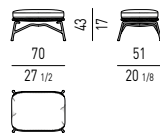

**FINITURA STRUTTURA  
STRUCTURE FINISH**

**ALLUMINIO | ALUMINUM**



**FINITURE CORDA  
CORD FINISHES**

**PELLE | LEATHER**

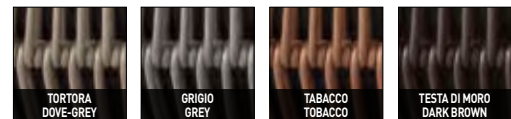

**LANCE** *Rodolfo Dordoni design*

**POLTRONCINA | LITTLE ARMCHAIR**

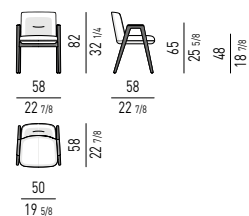

**SEDIA | CHAIR**

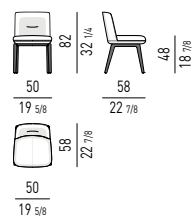

**FINITURE GAMBE  
LEGS FINISHES**

**ROVERE | OAK**



**FINITURE BRACCIOLO  
ARMREST FINISHES**

**PELLE ASPEN | ASPEN LEATHER**



**DAMIER** *Rodolfo Dordoni design*

**POUF | OTTOMANS**

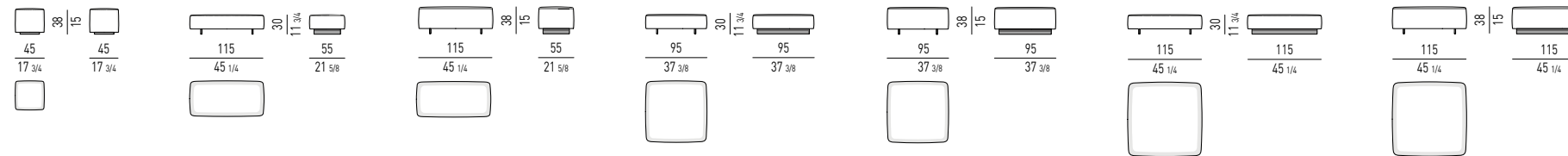

**ISOLA DAMIER MIX 01 | DAMIER ISLAND MIX 01**

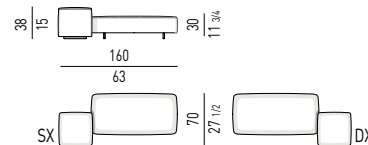

ELEMENTO COMPOSTO DA / ELEMENT COMPOSED BY:  
1 pouf/ottoman cm 45x45 h38  
1 pouf/ottoman cm 115x55 h30

**ISOLA DAMIER HIGH 01 | DAMIER ISLAND HIGH 01**

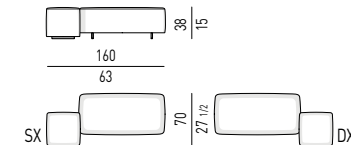

ELEMENTO COMPOSTO DA / ELEMENT COMPOSED BY:  
1 pouf/ottoman cm 45x45 h38  
1 pouf/ottoman cm 115x55 h30

**ISOLA DAMIER MIX 02 | DAMIER ISLAND MIX 02**

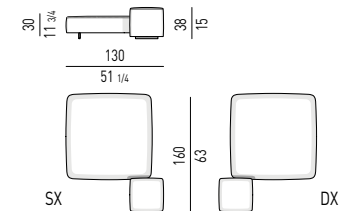

ELEMENTO COMPOSTO DA / ELEMENT COMPOSED BY:  
1 pouf/ottoman cm 45x45 h38  
1 pouf/ottoman cm 115x115 h30

**ISOLA DAMIER HIGH 02 | DAMIER ISLAND HIGH 02**

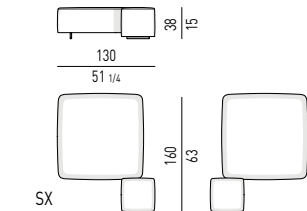

ELEMENTO COMPOSTO DA / ELEMENT COMPOSED BY:  
1 pouf/ottoman cm 45x45 h38  
1 pouf/ottoman cm 115x115 h30

**ISOLA DAMIER MIX 03 | DAMIER ISLAND MIX 03**

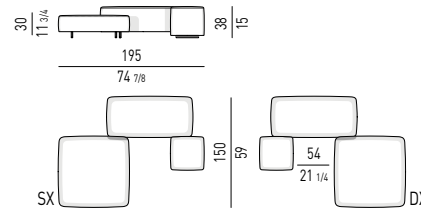

ELEMENTO COMPOSTO DA / ELEMENT COMPOSED BY:  
1 pouf/ottoman cm 45x45 h38  
1 pouf/ottoman cm 115x55 h38  
1 pouf/ottoman cm 95x95 h30

**ISOLA DAMIER HIGH 03 | DAMIER ISLAND HIGH 03**

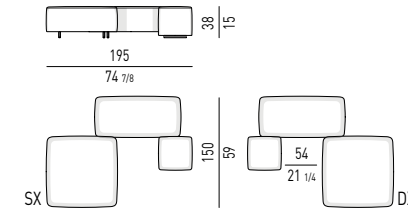

ELEMENTO COMPOSTO DA / ELEMENT COMPOSED BY:  
1 pouf/ottoman cm 45x45 h38  
1 pouf/ottoman cm 115x55 h38  
1 pouf/ottoman cm 95x95 h38

**ISOLA DAMIER MIX 04 | DAMIER ISLAND MIX 04**

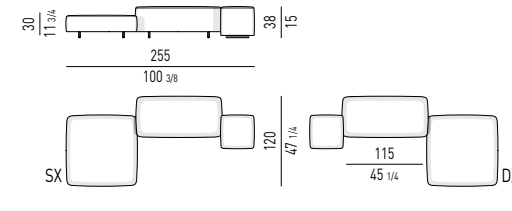

ELEMENTO COMPOSTO DA / ELEMENT COMPOSED BY:  
1 pouf/ottoman cm 45x45 h38  
1 pouf/ottoman cm 115x55 h38  
1 pouf/ottoman cm 95x95 h30

**ISOLA DAMIER HIGH 04 | DAMIER ISLAND HIGH 04**

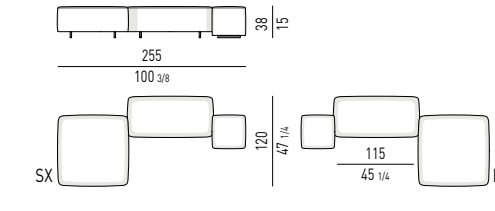

ELEMENTO COMPOSTO DA / ELEMENT COMPOSED BY:  
1 pouf/ottoman cm 45x45 h38  
1 pouf/ottoman cm 115x55 h38  
1 pouf/ottoman cm 95x95 h38

**ISOLA DAMIER MIX 05 | DAMIER ISLAND MIX 05**

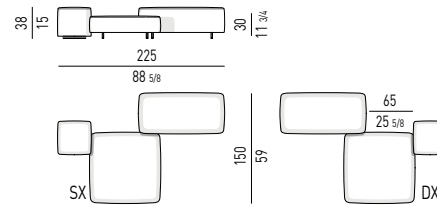

ELEMENTO COMPOSTO DA / ELEMENT COMPOSED BY:  
1 pouf/ottoman cm 45x45 h38  
1 pouf/ottoman cm 115x55 h38  
1 pouf/ottoman cm 95x95 h30

**ISOLA DAMIER HIGH 05 | DAMIER ISLAND HIGH 05**

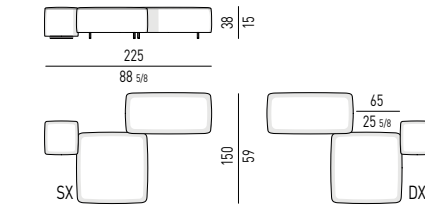

ELEMENTO COMPOSTO DA / ELEMENT COMPOSED BY:  
1 pouf/ottoman cm 45x45 h38  
1 pouf/ottoman cm 115x55 h38  
1 pouf/ottoman cm 95x95 h38

**FINITURA BASE  
BASE FINISH**

**METALLO | METAL ALLUMINIO | ALUMINUM**

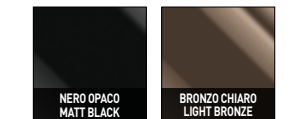

SOLO PER CM 45X45  
CM 45X45 ONLY

**BENDER** Rodolfo Dordoni design

**TAVOLINI | COFFEE TABLES**

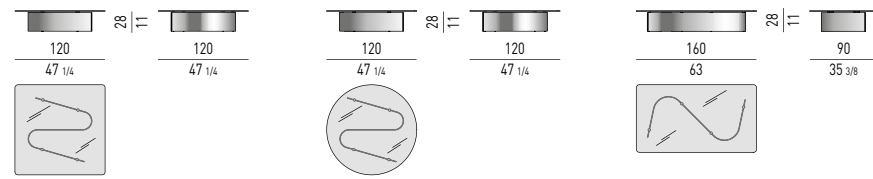

**SIDE TABLES**

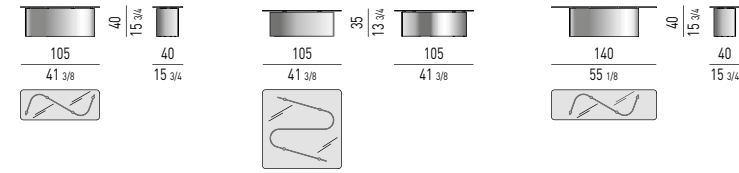

**FINITURA PIANO  
TOP FINISH**

**VETRO | GLASS**



**FINITURE BASE  
BASE FINISHES**

**ALLUMINIO | ALUMINUM**

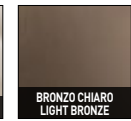

**ALLUMINIO | ALUMINUM**

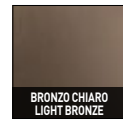
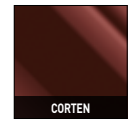

**RAYS** Rodolfo Dordoni design

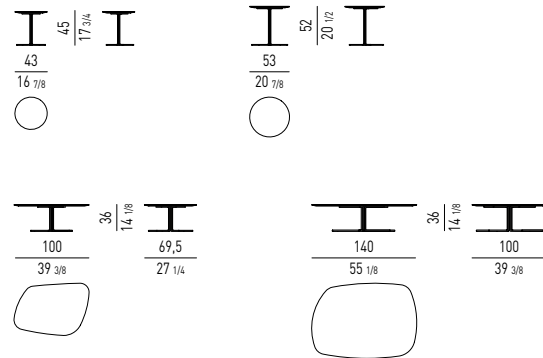

**FINITURE PIANO  
TOP FINISHES**

**MARMO | MARBLE**



**ROVERE | OAK**



**FINITURA STRUTTURA  
STRUCTURE FINISH**

**ALLUMINIO | ALUMINUM**



**OLIVER** Rodolfo Dordoni design

**TAVOLINI | COFFEE TABLES**

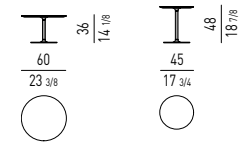

**TAVOLI "LOUNGE" | "LOUNGE" TABLES**

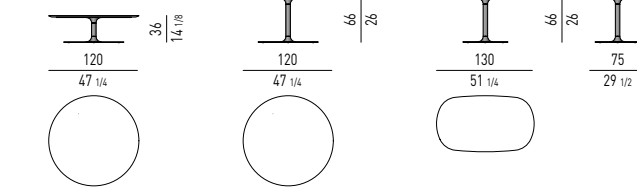

**FINITURE PIANO  
TOP FINISHES**

**MARMO | MARBLE**



**FINITURE BASE E PIASTRA  
BASE AND PLATE FINISHES**

**METALLO | METAL**



**MILTON** Rodolfo Dordoni design

**TAVOLINI | COFFEE TABLES**

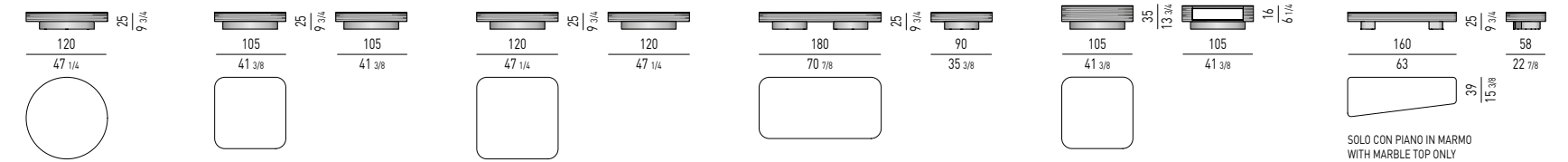

SOLO CON PIANO IN MARMO  
WITH MARBLE TOP ONLY

**COMODINI CON CASSETTI | NIGHTSTANDS WITH DRAWERS**

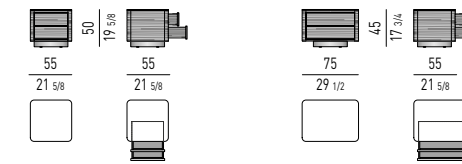

**COMODINI CON VANO PASSANTE | NIGHTSTANDS OPEN ON BOTH SIDES**

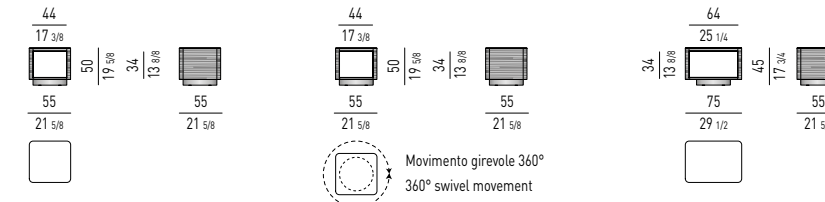

**FINITURE PIANO  
TOP FINISHES**

**MARMO | MARBLE**



**VETRO | GLASS**



**FINITURA STRUTTURA  
STRUCTURE FINISH**

**ROVERE | OAK**



**FINITURA BASE E VANO INTERNO  
BASE AND INTERNAL SECTION FINISH**

**METALLO | METAL**

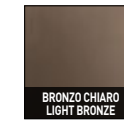

RING *nendo design*

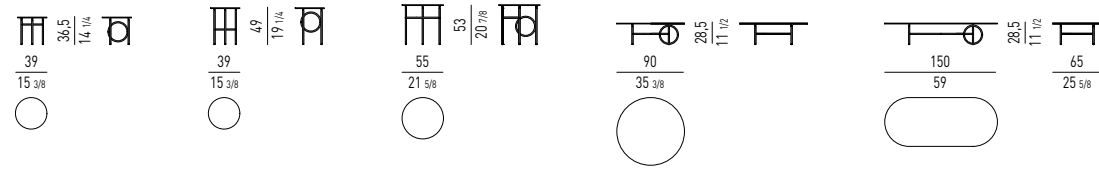

FINITURE PIANO  
TOP FINISHES



FINITURE BASE  
BASE FINISHES

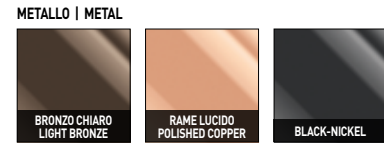

WAVES *nendo design*

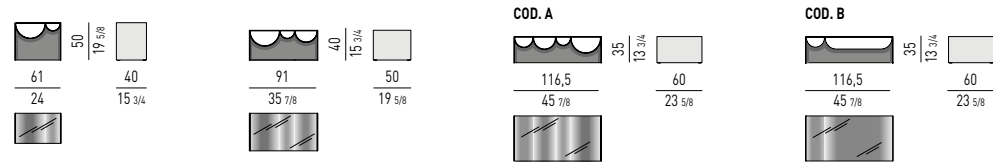

FINITURA PIANO  
TOP FINISH



FINITURE STRUTTURA  
STRUCTURE FINISHES



SHIELDS *Minotti Studio design*

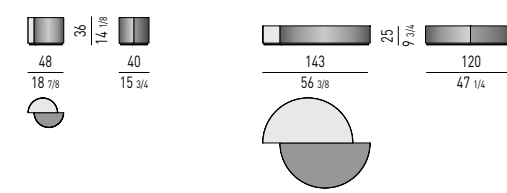

FINITURE PIANO  
TOP FINISHES



FINITURA STRUTTURA  
STRUCTURE FINISH



BODEN *Gordon Guillaumier design*

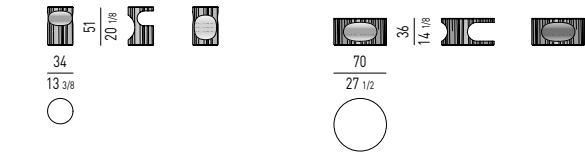

FINITURE PIANO  
TOP FINISHES

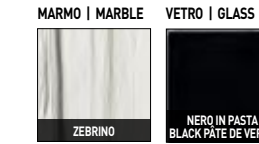

FINITURA STRUTTURA ESTERNA  
EXTERNAL STRUCTURE FINISH



FINITURA STRUTTURA INTERNA  
INNER STRUCTURE FINISH



CARSON "BOOKCASE" *Rodolfo Dordoni design*

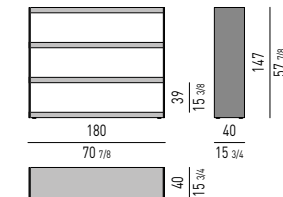

FINITURA FIANCHI  
SIDES FINISH



FINITURA RIPIANI  
SHELVES FINISH

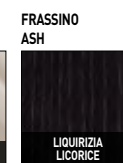

FINITURA FIANCHI  
SIDES FINISH



FINITURA RIPIANI  
SHELVES FINISH



FINITURA FIANCHI  
SIDES FINISH

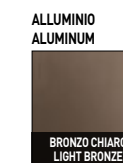

FINITURA RIPIANI  
SHELVES FINISH

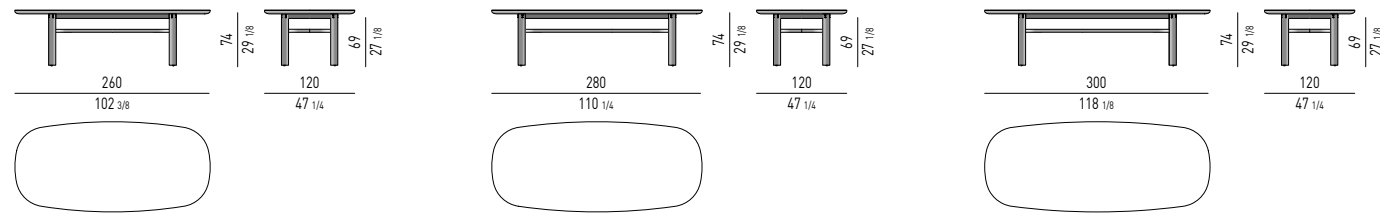
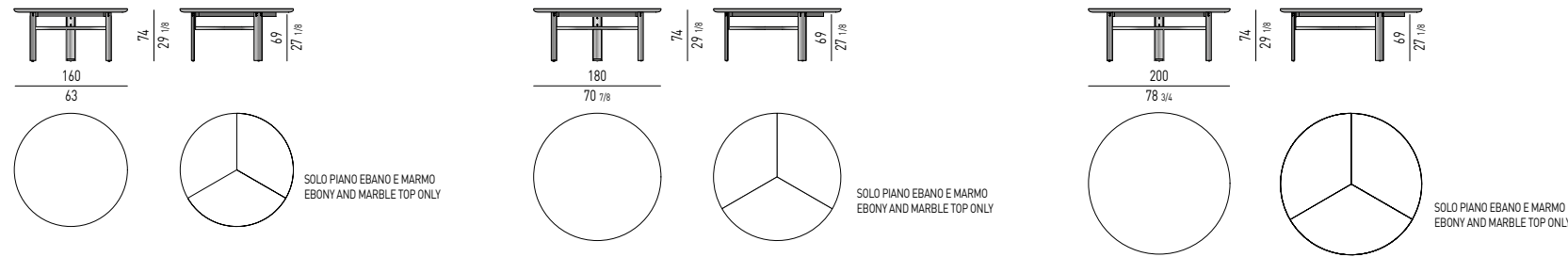

**DAN** *Christophe Delcourt design*

**FINITURE PIANO**  
TOP FINISHES

**FINITURA SOTTOPIANO**  
UNDER-PANEL FINISH

**FINITURA ESTERNA GAMBE**  
EXTERNAL LEGS FINISH

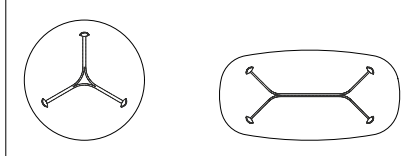
**FINITURE INTERNE GAMBE E TELAIO**  
INTERIOR LEGS AND CROSSPIECE FINISHES

**POSIZIONE GAMBE** | LEGS POSITION

**FINITURE INTERNE GAMBE E TELAIO**  
INTERIOR LEGS AND CROSSPIECE FINISHES

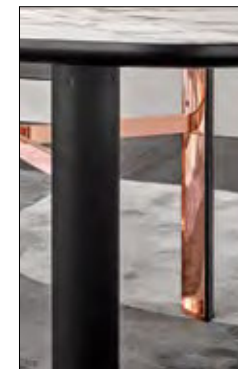
**BRONZO CHIARO** | LIGHT BRONZE

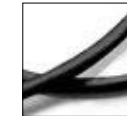
**RAME LUCIDO** | POLISHED COPPER

**CAVO ELETTRICO**  
ELECTRIC CORD

**RIVESTITO IN POLIESTERE NERO**  
BLACK POLYESTER COVERED

**LUNGHEZZA CAVO**  
CORD LENGTH

**INTERRUTTORE ON/OFF**  
ON/OFF SWITCH

**LAMPADA DA TAVOLO**  
TABLE LAMP

**LAMPADA DA TERRA**  
FLOOR LAMPS

**FINITURA PARALUME**  
LAMP SHADE FINISH

**TESSUTO**  
FABRIC

**STRUTTURA INTERNA**  
INTERNAL STRUCTURE

**METALLO**  
METAL

**FINITURA SUPPORTI**  
SUPPORTS FINISH

**METALLO**  
METAL

**FINITURA PIEDINI**  
FEET FINISH

**PVC**

**EMISSIONE LUMINOSA**  
LIGHT OUTPUT

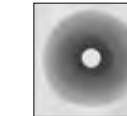
**DIFFUSA**  
DIFFUSE

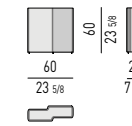
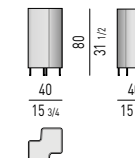
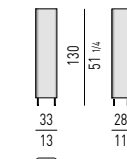
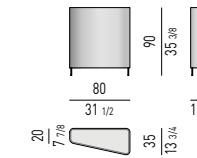
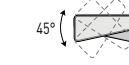
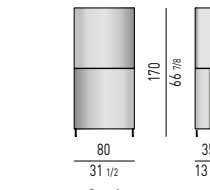
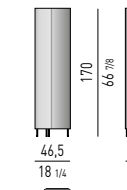
 SOLO LAMPADA DA TERRA  
FOR FLOOR LAMP ONLY

**BLANCHE** *Minotti Studio design*
**LAMPADA DA TAVOLO**  
TABLE LAMP

**LAMPADA DA TERRA**  
FLOOR LAMPS

**NEW 2018**

**NEW 2018**

 Rotazione paralume superiore di 45°  
Rotation upper lampshade of 45°

**NEW 2018**
**LAMPADINE**

 Lampada da tavolo H.60  
4xMax.20W - LED E14

 Lampada da terra H.80 / H.90  
4xMax.20W - LED E27

 Lampada da terra H.130  
6xMax.20W - LED E27

 Lampada da terra H.170  
8xMax.20W - LED E27

 CLASSE 1  
Automarcatura CE

**ATTENZIONE:** per ridurre il rischio di surriscaldamento,  
attenersi alle indicazioni riportate sopra.

**LIGHT BULBS**

 Table lamp H.60  
4x Max. 20W - E14 LED

 Floor lamp H.80 / H.90  
4x Max. 20W - E27 LED

 Floor lamp H.130  
6x Max. 20W - E27 LED

 Floor lamp H.170  
8x Max. 20W - E27 LED

 CLASS 1  
CE marked

**CAUTION:** to limit the risk of overheating, please follow  
the instructions indicated above.

**LEUCHTMITTEL**

 Tischlampe H.60  
4xMax.20W - E14 LED-Lampen

 Bodenleuchte H.80 / H.90  
4xMax.20W - E27 LED-Lampen

 Bodenleuchte H.130  
6xMax.20W - E27 LED-Lampen

 Bodenleuchte H.170  
8xMax.20W - E27 LED-Lampen

 KLASSE 1  
CE-Kennzeichnung

**ACHTUNG:** Um das Risiko der Überhitzung zu  
vermindern, die oben genannten Anweisungen  
einhalten.

**AMPOULES**

 Lampe de table H.60  
4xMax 20W - LED E14

 Lampadaire H.80 / H.90  
4xMax 20W - LED E27

 Lampadaire H.130  
6xMax 20W - LED E27

 Lampadaire H.170  
8xMax 20W - LED E27

 CLASSE 1  
Marquage EC

**ATTENTION :** afin de prévenir tout risque de surchauffe,  
suivre les indications ci-dessus.



**CONTENITORE ORIZZONTALE "DINING" | HORIZONTAL "DINING" SIDEBOARD**

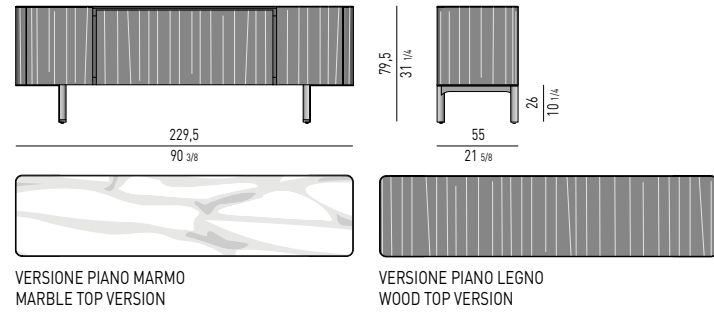

**CONTENITORE ORIZZONTALE "LIVING" LOW | HORIZONTAL SIDEBOARD "LIVING" LOW**

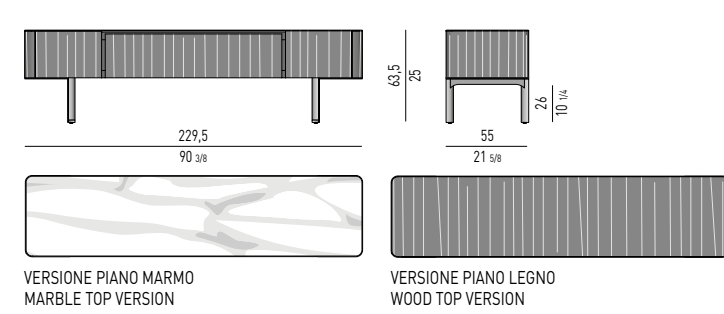

**CONTENITORE ORIZZONTALE "LIVING" HIGH | HORIZONTAL SIDEBOARD "LIVING" HIGH**

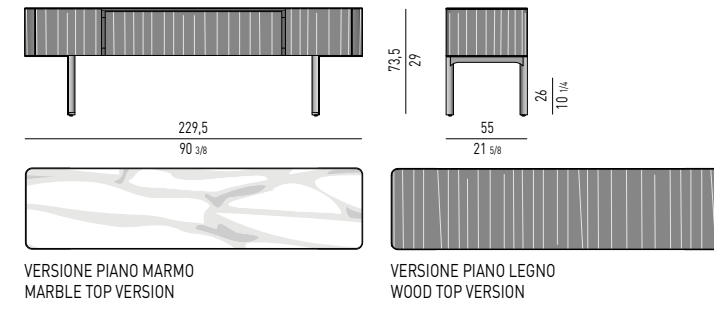

**CONSOLE "LIVING/TV" | "LIVING/TV" CONSOLE**

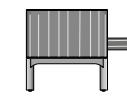
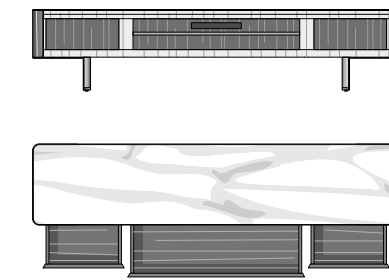
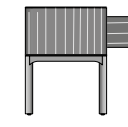
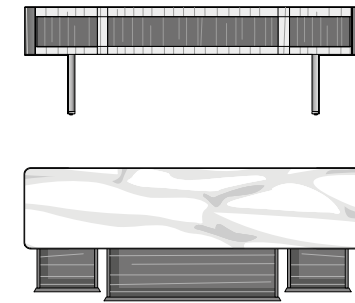
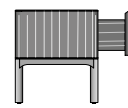
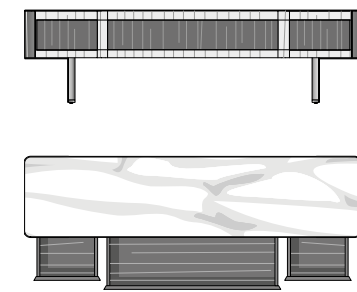
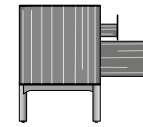
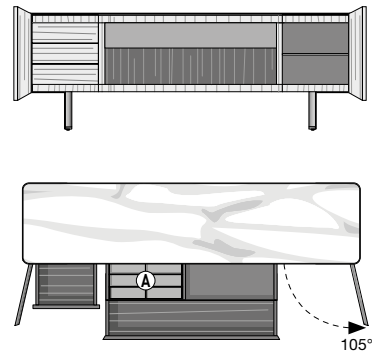
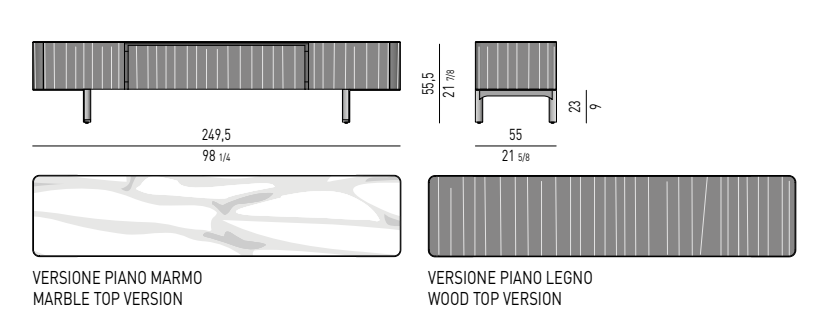

1	
2	2
2	2
2	2

**[A] VASSOIO PORTAPOSATE / CUTLERY TRAY**  
 Scomparto / Section 1: cm 50x7,5xh2,7  
 Scomparto / Section 2: cm 24,5x8xh2,7

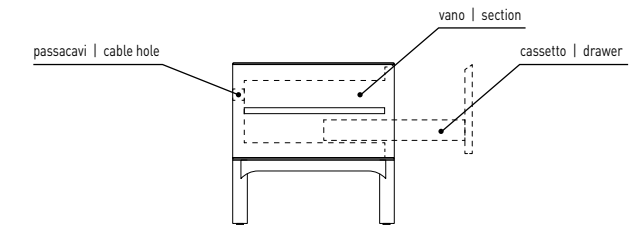
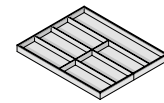

**CONTENITORE "BAR" | "BAR" SIDEBORD**

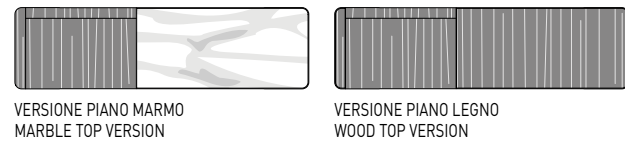
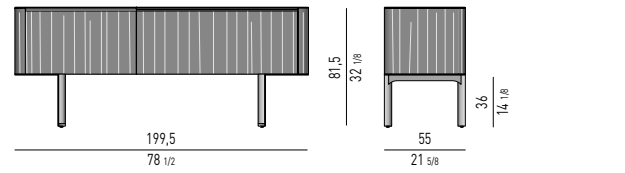

**CONSOLLE | CONSOLE TABLE**

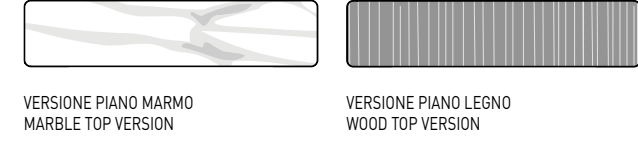
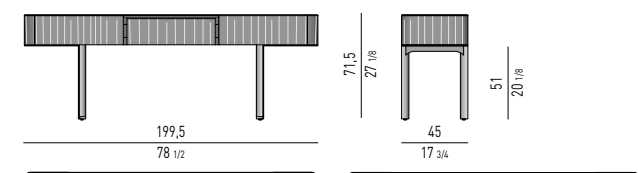

**CONTENITORE "NIGHT" | "NIGHT" SIDEBORD**

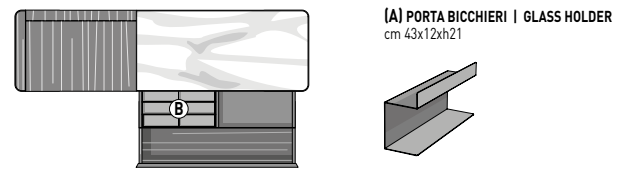
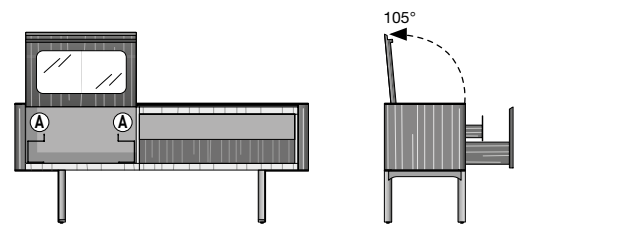
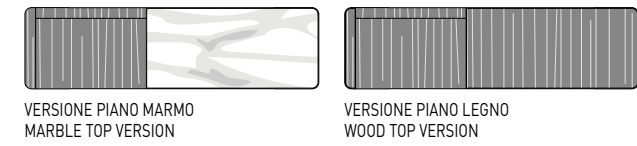
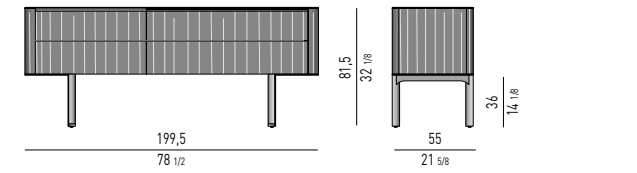

**[B] VASSOIO PORTAPOSATE / CUTLERY TRAY**  
 Scosparto / Section 1: cm 50x7,5xh2,7  
 Scosparto / Section 2: cm 24,5x8xh2,7

1	
2	2
2	2
2	2

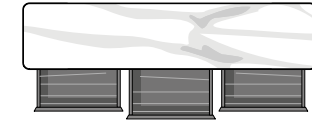
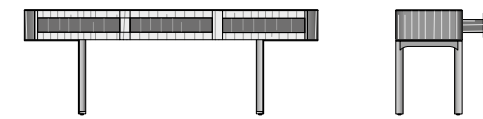

**[A] VASSOIO PORTA OGGETTI / JEWELRY TRAY TRAY**  
 Scosparto / Section 1: cm 24x8xh6  
 Scosparto / Section 2: cm 15x9xh6  
 Scosparto / Section 3: cm 7,5x15xh6  
 Scosparto / Section 4: cm 15x18xh6

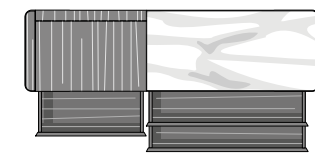
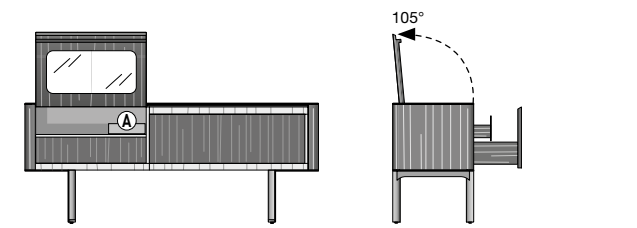

1	
2	3
2	3
4	3

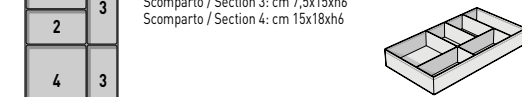

**FINITURA STRUTTURA, ANTE, CASSETTI E FIANCHI DEL VANO INTERNO**  
 STRUCTURE, DOORS, DRAWERS AND INTERNAL COMPARTMENT SIDE PANELS FINISH

FRASSINO | ASH



FRASSINO | ASH



EBANO | EBONY



FINITURA INTERNA DEL VANO CON PIANO A RIBALTA

FLIP-UP TOP INTERNAL COMPARTMENT FINISH

ACCIAIO | STEEL

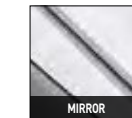

FINITURA INTERNA DEL VANO INTERNAL COMPARTMENT FINISH

LACCATO | LACQUERED



**FINITURE PIANO TOP FINISHES**

MARMO | MARBLE



MARMO | MARBLE



MARMO | MARBLE



FRASSINO | ASH



FRASSINO | ASH



EBANO | EBONY



FINITURA FRONTALE CASSETTO INTERNO

INTERNAL DRAWER FRONT FINISH

METALLO | METAL



FINITURA FONDO CASSETTI

BOTTOM DRAWERS FINISH

CUOIO | SADDLE-HIDE



FINITURA VASSOI PORTAPOSATE E PORTAOGGETTI

CUTLERY AND JEWELLERY TRAY FINISH

CUOIO | SADDLE-HIDE



FINITURA GAMBE LEGS FINISH

METALLO | METAL

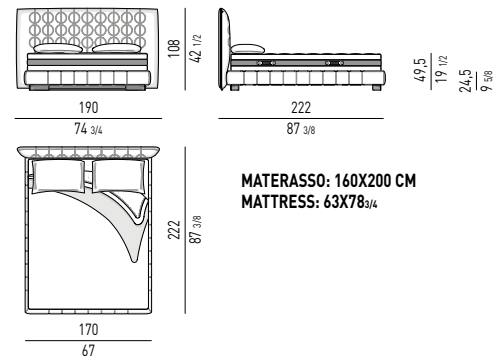

CURTIS *Rodolfo Dordoni design*

## QUEEN SIZE

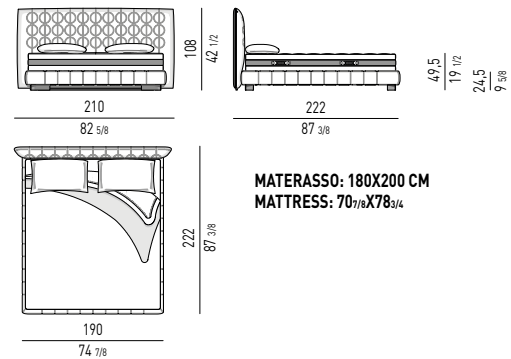
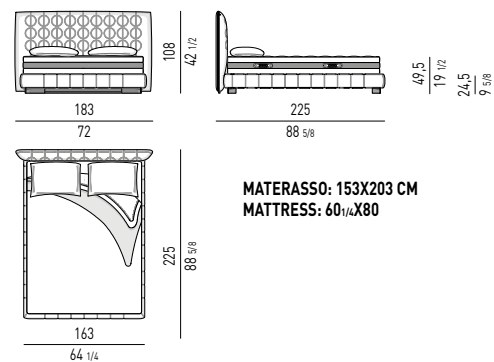

## KING SIZE

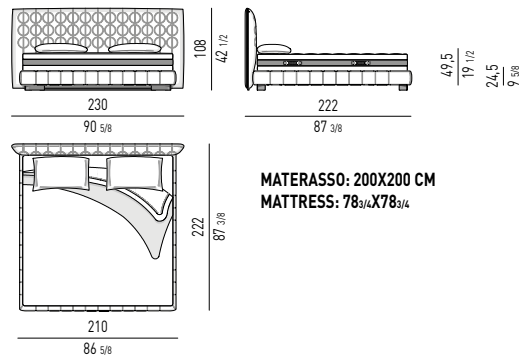
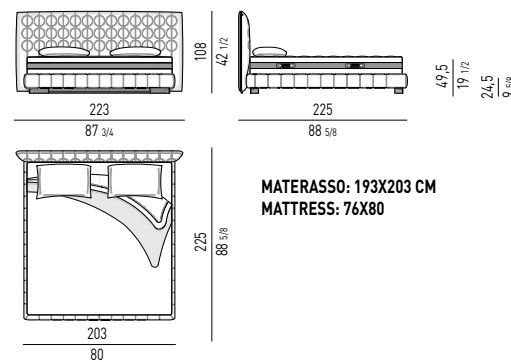
TESTATA RIVESTITA IN TESSUTO  
HEADBOARD COVERED IN FABRICTESTATA RIVESTITA IN PELLE  
HEADBOARD COVERED IN LEATHERFINITURA BASE  
BASE FINISH

ALLUMINIO | ALUMINUM

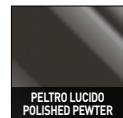

## SOMMIER INTERO

La testata viene agganciata attraverso un sistema di innesto e sgancio rapido.

## SOMMIER EINTEILIG

Das Kopfteil wird mit einem schnellen Stecksystem am Gestell angebracht.

## ONE PIECE SOMMIER

The headboard is fastened through a quick set and release coupling system.

## SOMMIER ENTIER

La tête de lit se fixe à l'aide d'un mécanisme d'enclenchement et déclenchement rapide.

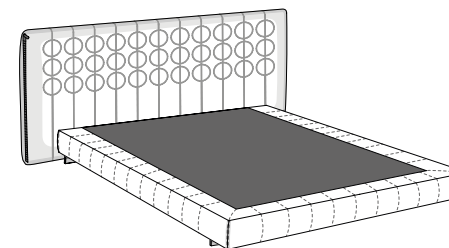
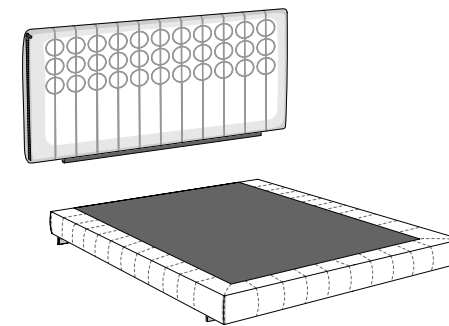

## SOMMIER DIVISO IN DUE ELEMENTI

Versione con sommier diviso in due elementi, al fine di facilitare la consegna. I due elementi si congiungono tra loro a mezzo di un'apposita cremagliera. La testata viene agganciata attraverso un sistema di innesto e sgancio rapido. I due elementi sommier vengono consegnati già rivestiti.

## SOMMIER ZWEITEILIG

Variante mit dem Sommier in zwei Teile zerlegt ist, um die Lieferung zu vereinfachen. Die beiden Elemente werden über ein spezifisches, zahnradähnliches Scharnier miteinander verbunden. Das Kopfteil wird mit einem schnellen Stecksystem am Gestell angebracht. Beide Sommier-Teile werden bereits bezogen geliefert.

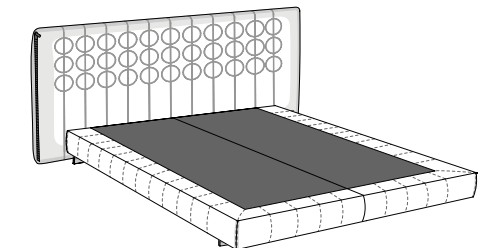
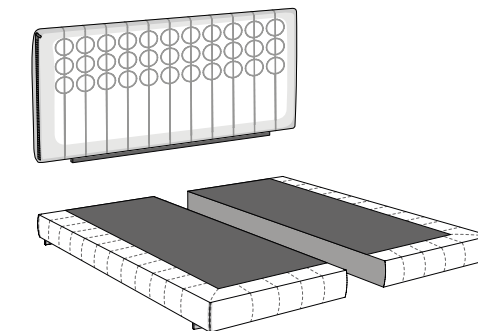

## SOMMIER DIVIDED INTO TWO PIECES

To facilitate delivery, a version with the sommier in two pieces is also available. The two pieces are joined by means of a special connecting device. The headboard is fastened through a quick set and release coupling system. The two sommier pieces are delivered with upholstery already in place.

## SOMMIER DIVISÉ EN DEUX PARTIES

Version avec sommier divisé en deux parties afin de faciliter la livraison. Les deux parties s'encastrent à l'aide d'un système de fixation à crémaillère. La tête de lit se fixe à l'aide d'un mécanisme d'enclenchement et déclenchement rapide. Les deux parties du sommier sont livrées avec leur revêtement.

## THE BOXSPRING TECHNOLOGY SOMMIER

La base del letto è costituita da un moderno sommier H 18 cm caratterizzato dalla presenza di molle insacchettate che, insieme al materasso "Comfort H25", favorisce un'elevata qualità del riposo notturno. L'appoggio a terra è affidato ad essenziali quanto sofisticate lame in metallo, H 6,5 cm, verniciato Peltro.

The base of the bed includes the modern cm 18 -high base with pocket springs that, along with the "Comfort H25" mattress, promises an extremely restful night's sleep. The bed rests on simple, but elegant Pewter colour metal blades, H 6,5 cm.

Das Bettgestell besteht aus einem modernen Polsterbett H 18 cm mit Taschenfedern, das gemeinsam mit der Matratze "Comfort H25" eine optimale Qualität des Nachtschlafs garantiert. Die Bodenaufgabe besteht aus ganz einfachen, aber raffinierten, zinnfarbig lackierten Metallleisten, H 6,5 cm.

La base du lit est constituée d'un moderne sommier H 18 cm caractérisé par la présence de ressorts ensachés qui, alliés au matelas "Comfort H25", favorisent un sommeil de bonne qualité. Il repose sur des lames, H 6,5 cm, essentielles et sophistiquées, en métal peint couleur Étain.

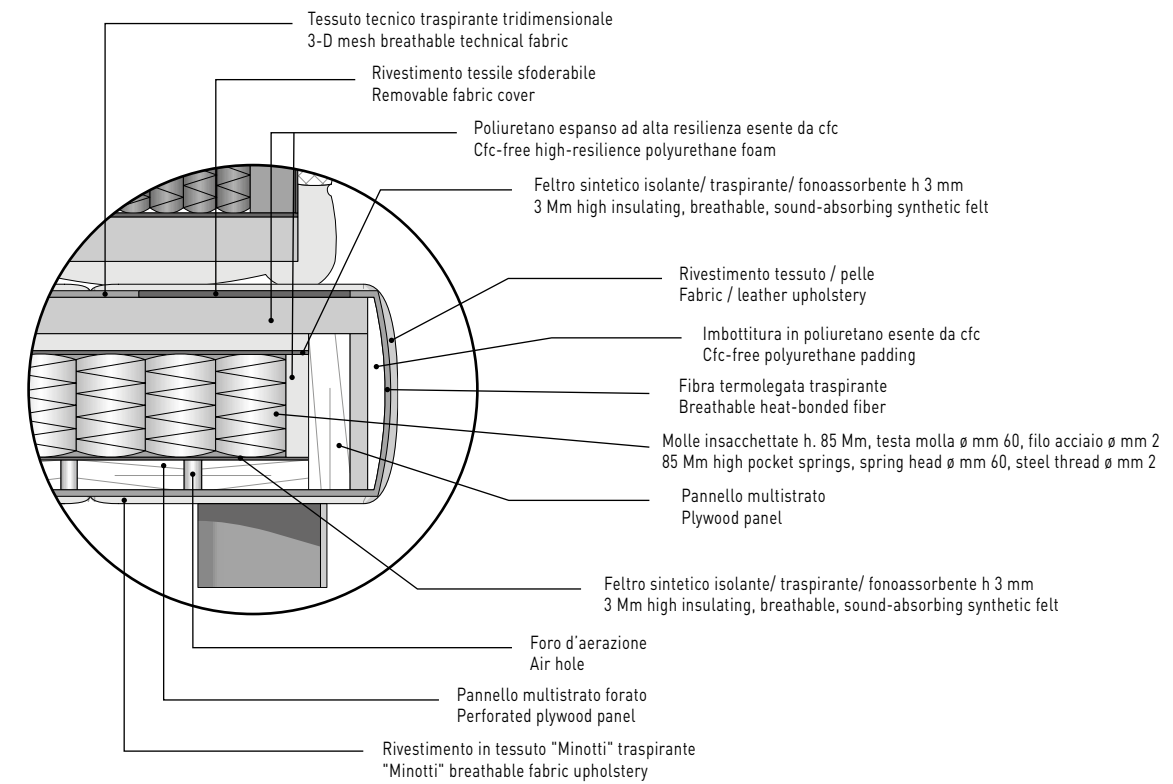
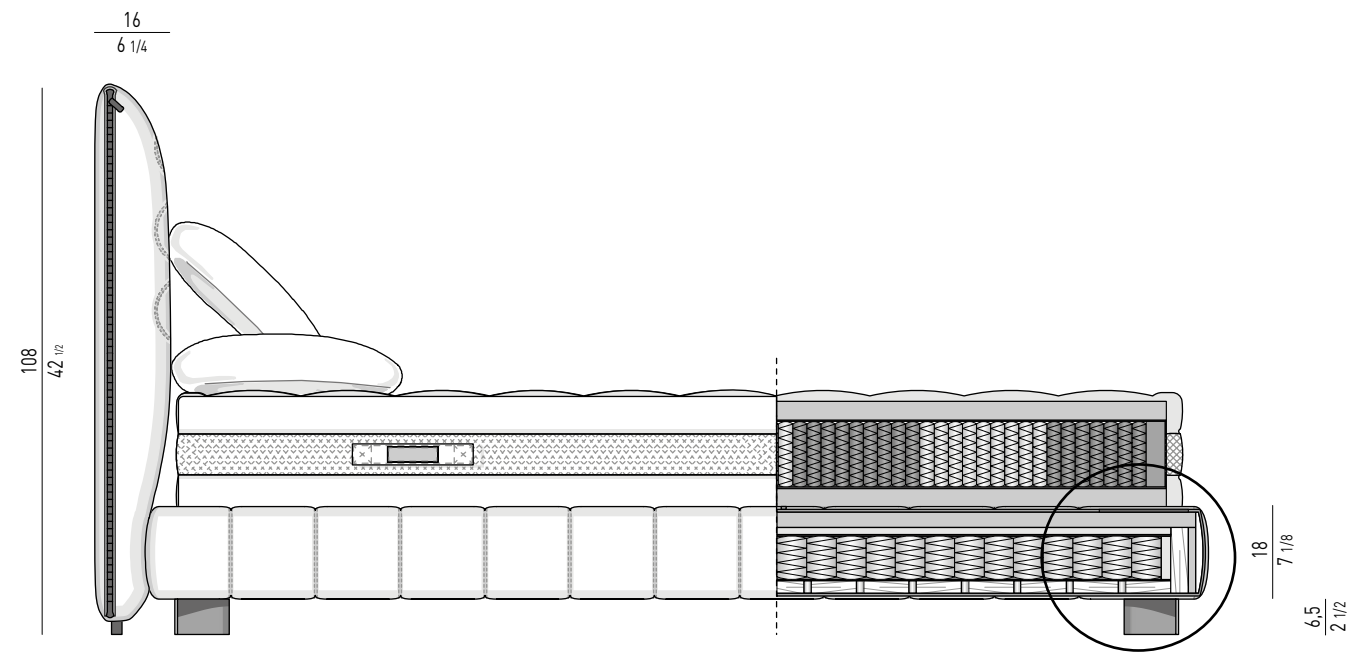

## MATERASSO | MATTRESS "COMFORT" H25

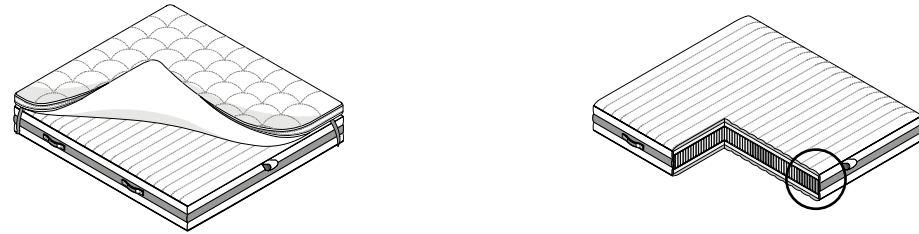

## DIMENSIONI MATERASSO | MATTRESS DIMENSIONS

160x200 / 63x78<sup>3/4</sup>  
 180x200 / 70<sup>7/8</sup>x78<sup>3/4</sup>  
 200x200 / 78<sup>3/4</sup>x78<sup>3/4</sup>  
 153x203 / 60<sup>1/4</sup>x80  
 193x203 / 76x80

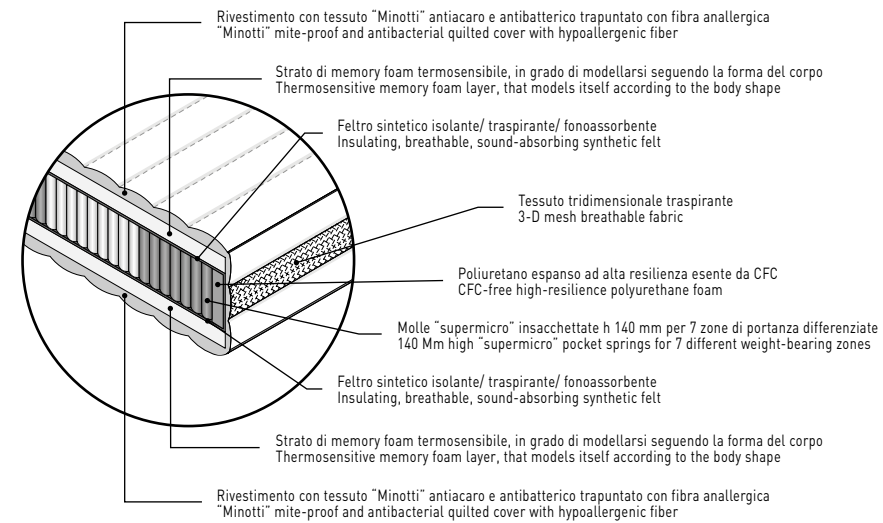

## MOLLEGGIO SUPER MICROPOCKET A 7 ZONE | SUPER MICROPOCKET 7-AREA SPRINGS

MORBIDEZZA STRAORDINARIA CON LA MOLLA CHE SI COMPRIME CON UN DITO  
 EXTRAORDINARY SOFTNESS OF THE SPRING WHICH COMPRESSES WITH THE PUSH OF A FINGER

N. ZONE DIFFERENZIATE | NO. OF DIFFERENTIATED AREAS  
 ALTEZZA MOLLA | HEIGHT OF SPRINGS  
 DIAMETRO TESTA MOLLA | SPRING HEAD DIAMETER  
 DIAMETRO FILO ACCIAIO | STEEL THREAD DIAMETER  
 CATEGORIA MOLLE (QUANTITÀ) CM 160X200 | SPRING CATEGORY (QUANTITY) CM 160X200

7  
 140 MM  
 25 MM  
 0,9 - 1,0 MM  
 3000

## TESSUTO TRIDIMENSIONALE TRASPIRANTE | 3-D MESH BREATHABLE FABRIC

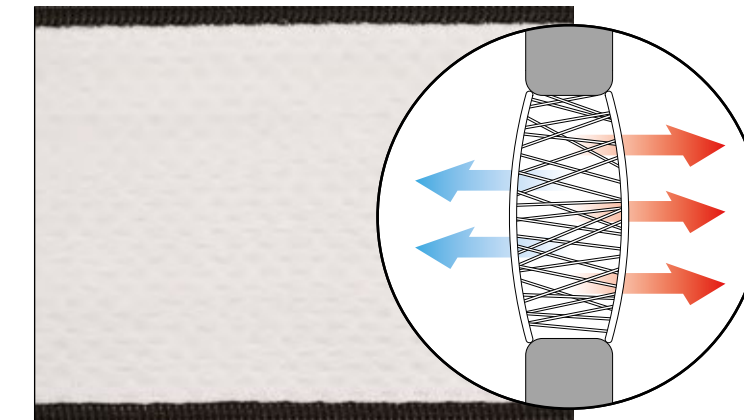

Tessuto tridimensionale composto da tre strati che generano un'intercapedine interna dove circola liberamente l'aria. Una fascia traspirante, che percorre il bordo del materasso, permette di mantenerlo più fresco e asciutto, grazie al flusso continuo d'aria che ne favorisce il riciccolo.

Three-dimensional material, consisting of three layers which create an internal three-dimensional gap where air can circulate freely. A transpiring hem runs along the edge of the mattress enabling it to stay fresher and drier, since the continuous airflow helps it recycle.

## MATERASSINO | TOPPER "COMFORT" H5

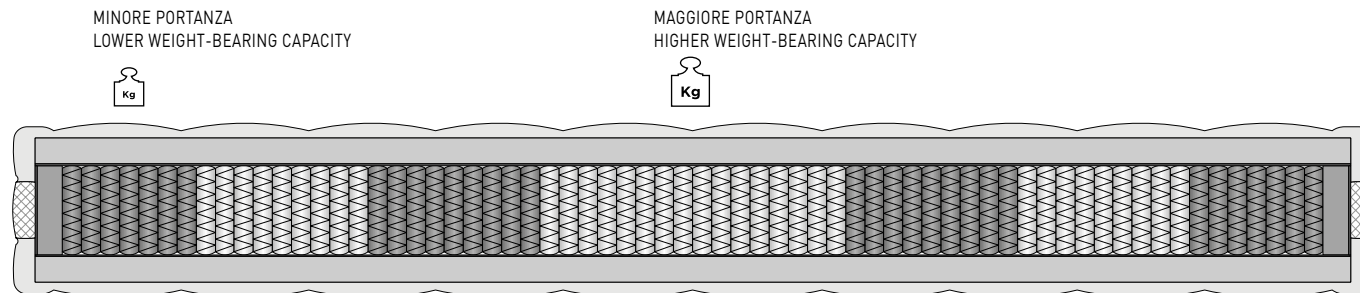

7 ZONE DI PORTANZA DIFFERENZIATE  
 7 DIFFERENT WEIGHT-BEARING ZONES

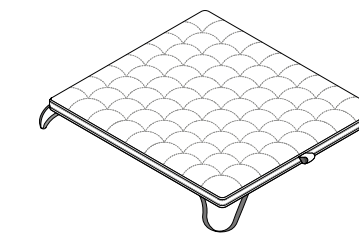

## DIMENSIONI TOPPER | TOPPER DIMENSIONS

160x200 / 63x78<sup>3/4</sup>  
 180x200 / 70<sup>7/8</sup>x78<sup>3/4</sup>  
 200x200 / 78<sup>3/4</sup>x78<sup>3/4</sup>  
 153x203 / 60<sup>1/4</sup>x80  
 193x203 / 76x80

LAWRENCE “THROW” *Rodolfo Dordoni design*

PLAID | THROW

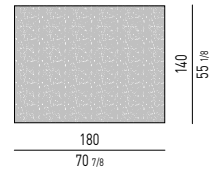

CURTIS BEDSPREAD *Minotti Studio design*

COPRILETTO | BEDSPREAD

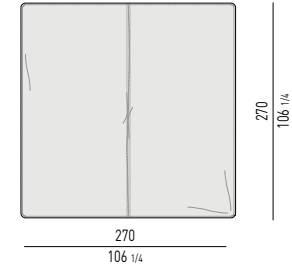

SET LENZUOLA LINO | LINEN SHEET SET

SET LENZUOLA | SHEET SET

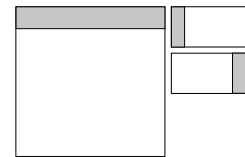

TEDDY *Minotti Studio design*

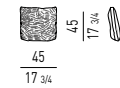

WISP *Minotti Studio design*

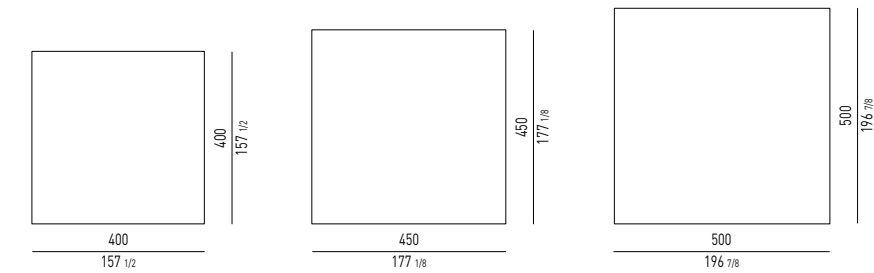
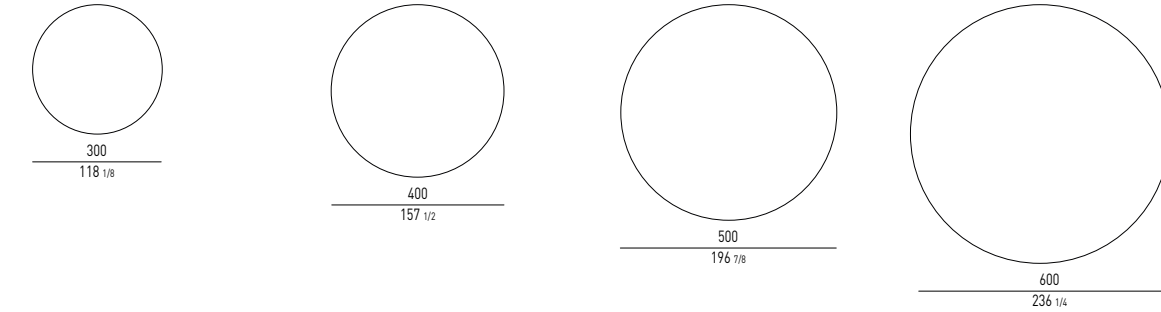
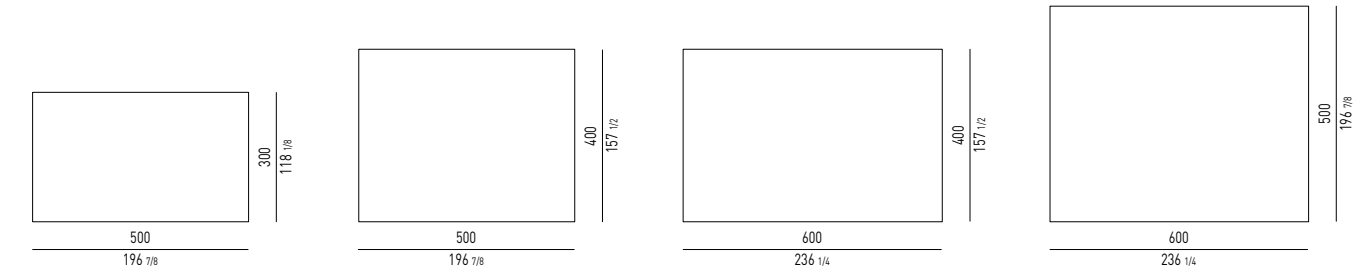

VARIANTI COLORE  
COLOUR VARIANTS

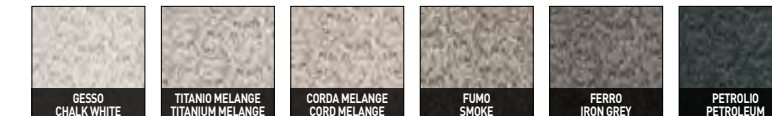

DIBBETS IPANEMA *Rodolfo Dordoni design*

DIBBETS IPANEMA SILVER

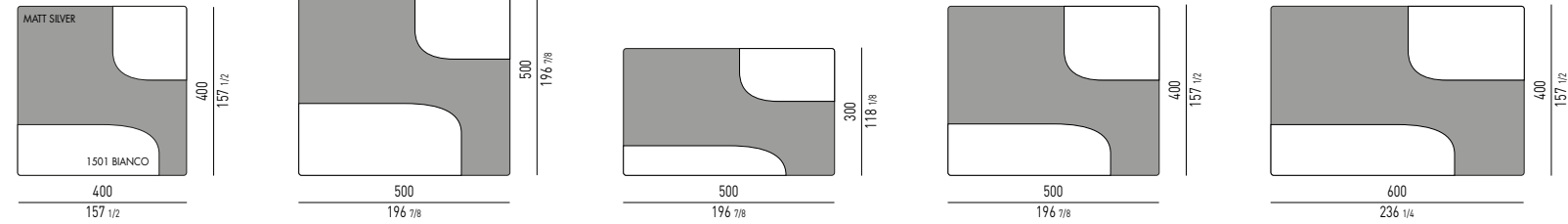

DIBBETS IPANEMA ECRU

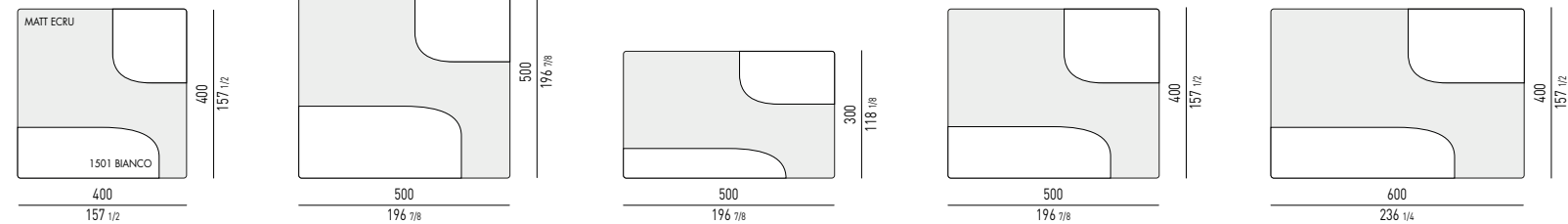

DIBBETS IPANEMA GREY

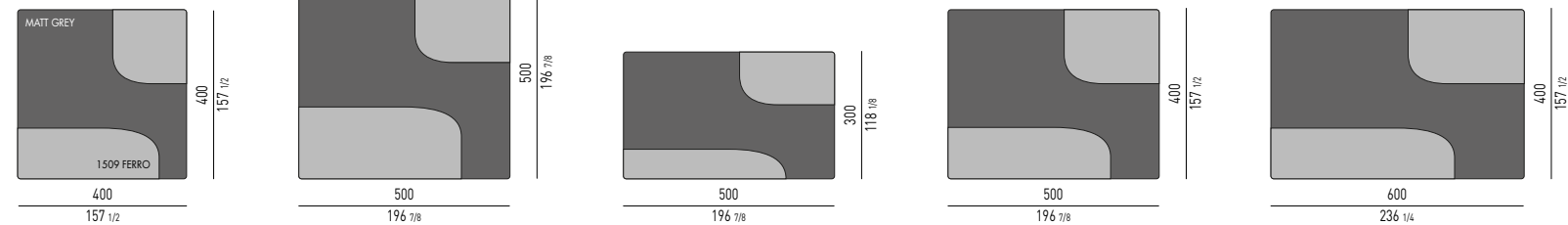

DIBBETS IPANEMA SILVER



DIBBETS IPANEMA ECRU



DIBBETS IPANEMA GREY



QUADRADO seating system *Marcio Kogan / studio mk27 design*

POLTRONA | ARMCHAIR

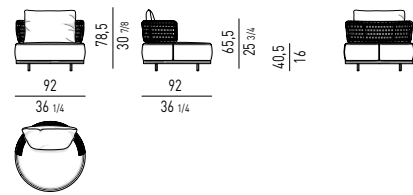

ELEMENTO ANGOLARE | CORNER ELEMENT

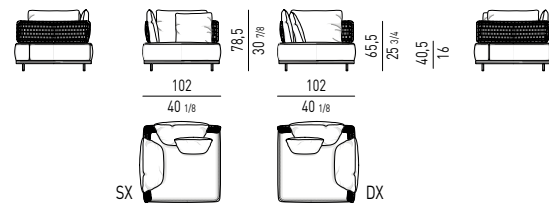

ELEMENTO CENTRALE | CENTRAL ELEMENT

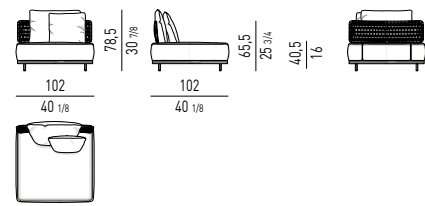

POUF | OTTOMANS

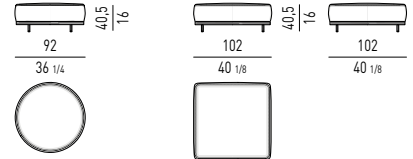

TAVOLINI | COFFEE TABLES

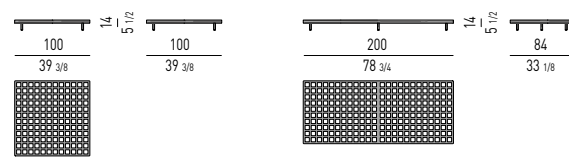

VASSOI | TRAYS

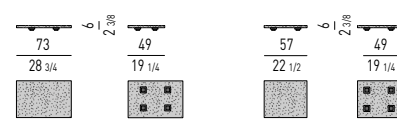

PORTACANDELA | CANDLE HOLDER

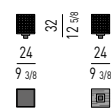

CUSCINO | CUSHION

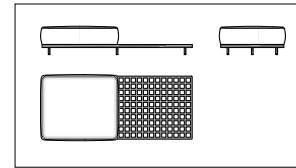
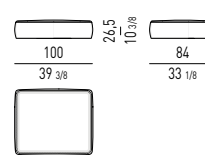

MODALITÀ DI UTILIZZO IN ABBINAMENTO AL TAVOLINO CM 200x84  
HOW TO USE THE CUSHION WITH CM 200x84 COFFEE TABLE

CUSCINI OPTIONAL | OPTIONAL CUSHIONS



OPTIONAL "RAIN COVER"



FINITURA BASE E TAVOLINI  
BASE AND COFFEE TABLES FINISH

LEGNO | WOOD

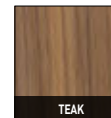

FINITURA STRUTTURA E PIEDINI  
STRUCTURE AND FEET FINISH

METALLO | METAL



FINITURE INTRECCIO  
BRAID FINISHES

FIBRA SINTETICA | SYNTHETIC FIBRE



FINITURA VASSOI  
TRAYS FINISH

PIETRA | STONE



YORK "CORD" OUTDOOR *Rodolfo Dordoni design*

OPTIONAL "RAIN COVER"

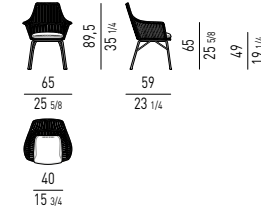

OPTIONAL "RAIN COVER"



FINITURE STRUTTURA  
STRUCTURE FINISHES

ALLUMINIO | ALUMINUM



FINITURE CORDA  
CORD FINISHES

FILATO INTRECCIATO | WOVEN FIBER

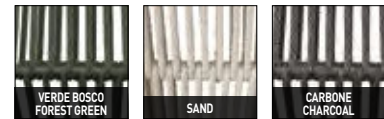

PRINCE "CORD" OUTDOOR *Rodolfo Dordoni design*

POLTRONA | ARMCHAIR

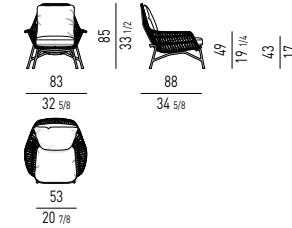

POGGIAPIEDI | FOOTSTOOL

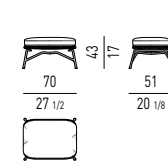

OPTIONAL "RAIN COVER"

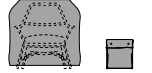

FINITURE STRUTTURA  
STRUCTURE FINISHES

ALLUMINIO | ALUMINUM



FINITURE CORDA  
CORD FINISHES

FILATO INTRECCIATO | WOVEN FIBER

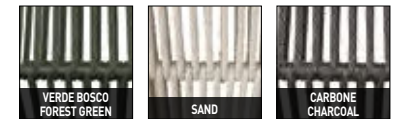

VAN DYCK "OUTDOOR" *Rodolfo Dordoni design*

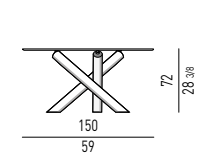

OPTIONAL "RAIN COVER"

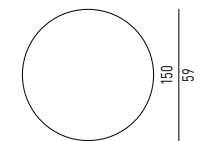

FINITURE PIANO  
TOP FINISHES

PIETRA | STONE



FINITURE STRUTTURA  
STRUCTURE FINISHES

METALLO | METAL



NEW 2018 FINISHES



DUCHAMP “OUTDOOR” *Rodolfo Dordoni design*

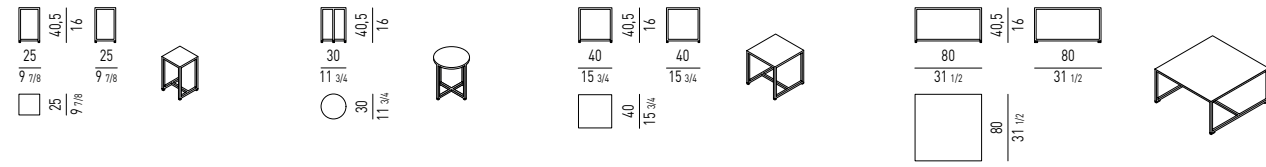

OPTIONAL “RAIN COVER”

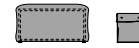

FINITURE STRUTTURA  
STRUCTURE FINISHES

ALLUMINIO | ALUMINUM



LEGER “OUTDOOR” *Rodolfo Dordoni design*

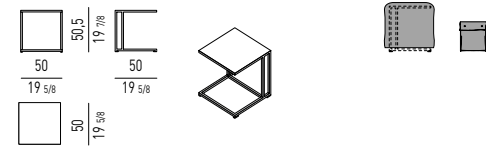

OPTIONAL “RAIN COVER”

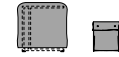

FINITURE STRUTTURA  
STRUCTURE FINISHES

ALLUMINIO | ALUMINUM

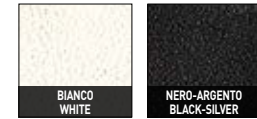

MINOTTI STUDIO

INTERIOR DECORATION  
COMMUNICATION  
GRAPHIC DESIGN  
PRODUCT ENGINEERING

MADE IN  
100% ITALY

Minotti S.p.A. si riserva  
la facoltà di modificare,  
in qualunque momento  
e senza preavviso,  
le caratteristiche tecniche  
dei modelli illustrati  
nel presente catalogo.  
**I colori stampati sono da considerarsi  
puramente indicativi.**

Minotti S.p.A. reserves  
the right to change,  
at any time and  
without prior warning,  
the technical specification  
of any product illustrated  
in this catalogue.  
**Printed colours are to be considered  
as purely indicative.**

**Minotti S.p.A.**  
via Indipendenza, 152  
20821 Meda (MB) - Italy  
t. +39 0362 343499  
f. +39 0362 340319  
e. info@minotti.it  
www.minotti.com

Per ulteriori informazioni  
vi invitiamo a visitare il nostro sito web.

For further information  
please visit our website.



www.minotti.com

Follow us on:       
#MINOTTI

È espressamente vietata  
qualsiasi riproduzione,  
copia o modifica,  
anche parziale, del presente  
catalogo.

Any reproduction,  
representation or  
modification, in full  
or partly, is expressly  
prohibited.

Printed: luglio | July 2018

Copyright © Minotti S.p.A. 2018  
All rights reserved



